



Low voltage AC drives

ABB industrial drives ACS880, single drives 0.55 to 3200 kW Catalog

What does all-compatible mean for you?

Being all-compatible means that drive choice should add value to your business. Drives should meet the unique demands of your processes, help you save energy and reduce operating costs. Also, all-compatible means that our drives are easy to select, use and maintain. These are the cornerstones making our industrial drive series the all-compatible choice.

Contents

3	The all-compatible ACS880 series drives
4	Simplifying your world without limiting your possibilities
5	Single drives, ACS880
6	Human all-compatible
7	Process all-compatible
8	Environment all-compatible
9	Business all-compatible
10	How to select a drive
10	Technical data
11	Wall-mounted single drives, ACS880-01
12-13	Ratings, types and voltages, ACS880-01
14	Cabinet-built single drives, ACS880-07
15-16	Ratings, types and voltages, ACS880-07
17	Cabinet-built regenerative single drives, ACS880-17
18	Ratings, types and voltages, ACS880-17
19	Cabinet-built low harmonic single drives, ACS880-37
20	Ratings, types and voltages, ACS880-37
21	Standard interface and extensions for comprehensive connectivity
22	Standard software for scalable control and functionality
23-24	Application control programs
25	Designed to control virtually any type of AC motor
26	Intuitive human-machine interface
26	PC tool for easy startup and maintenance
27	Integrated safety simplifies configuration
28	Drive application programming based on IEC standard 61131-3
29	Flexible connectivity to automation networks
30	Input/output extension modules for increased connectivity
30	Speed feedback interfaces for precise process control
30	I/O option extension adapter
30	DDCS communication option modules
30	Remote monitoring access worldwide
31	EMC – electromagnetic compatibility
32-35	Sine filters, ACS880-01, ACS880-07 and ACS880-17/-37
36	Brake options
36-37	Brake options, ACS880-01
38-39	Brake options, ACS880-07
40	Brake options, ACS880-37
41-42	du/dt filters
43	Dimensioning tool for selecting the optimal drive
45-47	Summary of features and options
48-49	Drive services

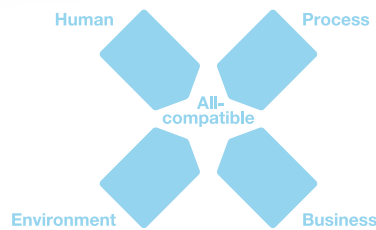

The all-compatible ACS880 series drives

The ACS880 series drives are part of ABB's all-compatible drives portfolio. Compatible with virtually all types of processes, automation systems, users and business requirements they are designed to tackle any motor-driven application, in any industry, whatever the power range. The innovation behind all-compatibility is our new drives architecture that simplifies operation, optimizes energy efficiency and helps maximize process output. The ACS880 series consists of single drives, multidrives and drive modules.

Simplifying your world without limiting your possibilities

Wide range of safety features

Safe torque off is built-in as standard. An optional safety functions module provides extended safety functions, simplifying the configuration and reducing installation space.



Direct torque control (DTC)

ABB's signature motor control technology provides precise speed and torque control for all applications and virtually any type of AC motor.



Application control programs

A range of ready-made programs to optimize application productivity and usability.

Removable memory unit

Stores all the software and parameter configurations in an easily replaceable and simple-to-install module.



Energy efficiency

The drive provides features such as an energy optimizer and energy efficiency information that help you monitor and save energy used in the processes.



Remote monitoring

With a built-in web server, NETA-21 enables worldwide access to drives.

Drive application programming

Customizable to meet the precise application needs based on IEC 61131-3. The drive is also easy to integrate with other ABB components such as PLC and HMI.



Drive-to-drive link

Allows fast communication between drives including master-follower configurations without any additional hardware.

Single drives, ACS880

The all-compatible drives are designed to provide customers across industries and applications with unprecedented levels of compatibility and flexibility.

Our ACS880 single drives are stand alone drives. They are customized to meet the precise needs of industries such as oil and gas, mining, metals, chemicals, cement, power plants, material handling, pulp and paper, sawmills, marine, water and wastewater, food and beverage and automotive. They control a wide range of applications such as cranes, extruders, winches, winders, conveyors, mixers, compressors, centrifuges, test benches, elevators, extruders, pumps and fans.



Intuitive human-machine interface

Intuitive, high-contrast and high-resolution display enabling easy navigation in multiple languages.



Startup and maintenance tool

PC tool for drive startup, configuration and daily use and process tuning. PC tool is connected to the drive via Ethernet or USB interface.



Communication with all major automation networks

Fieldbus adapters enable connectivity with all major automation networks.



Extended connectivity

In addition to the standard interfaces, the drive has three built-in slots for additional input/output extension modules and speed feedback interfaces.

Flexible product configurations

Drives are built to order with a wide range of options such as EMC filters, braking options and different enclosure variants.



Human all-compatible

The new drives share easy-to-use interfaces saving you time during drive commissioning and maintenance. When you have learned it once, you can use it with all the drives in our all-compatible drives portfolio.

The new control panel supports over 20 languages. The new PC tool provides extensive drive monitoring capabilities and quick access to the drive settings. Integrated and certified safety features provide safety for machine operators.

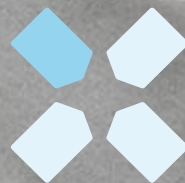



Process all-compatible

The drives are compatible with all kinds of processes. They control virtually any type of AC motor, provide extensive input/output connectivity and support all major fieldbus protocols. The drives cover a wide voltage and power range. Control performance is scalable from basic to demanding applications delivered by direct torque control (DTC). The flexibility and scalability of the drives enable one drive platform to control virtually any application or process, making your drive selection easy.



Environment all-compatible



There is an increased demand for reducing industries' impact on the environment. Our drives can help you reduce energy consumption in a wide range of applications. The new drives have an energy optimizer feature that ensures maximum torque per ampere, reducing energy drawn from the supply. The built-in energy efficiency calculators help you to analyze and optimize processes. We can help you to investigate the energy saving potential of selected applications with our six-step energy appraisal. Our services expand through the life cycle of the drive and help you maintain energy efficiency from installation and commissioning to drive replacement.





Business all-compatible



The new all-compatible drives are not just equipment but part of your business strategy. Providing better control over your processes, the new drives equal lower energy consumption, improved productivity, flexibility and ease of use. In addition to drives we offer a wide range of products and services to support your business. With offices in over 90 countries and a global technical partner network, we are in a good position to offer technical advice and local support, worldwide.

How to select a drive

Many of the features for the ACS880 single drives are built-in as standard, making selection easy. A wide range of options are available to optimize the drive for different requirements. To choose the right drive for your application, please refer to the rating tables on page 12, 13, 15, 16, 18 and 20 or use ABB's DriveSize dimensioning tool (page 43). The selected

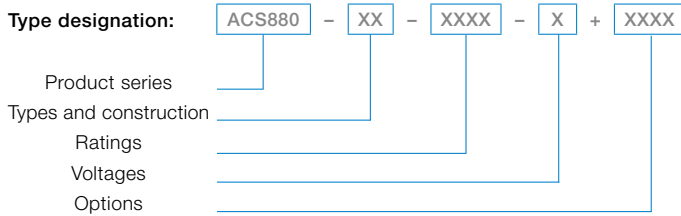

drive has a unique type designation, which identifies the drive by construction, power and voltage range. The options are added to the type designation with a "plus" code. Build up your own ordering code using the type designation key or contact your local ABB drives sales office and let them know your needs/requirements.



Technical data

Mains connection

Voltage and power range	3-phase, $U_{N2} = 208$ to 240 V, +10/-15% (-01) 3-phase, $U_{N3} = 380$ to 415 V, +10/-15% (-01), ±10% (-07,-17,-37) 3-phase, $U_{N5} = 380$ to 500 V, +10/-15% (-01), ±10% (-07,-17,-37) 3-phase, $U_{N7} = 525$ to 690 V, +10/-15% (-01), ±10% (-07,-17,-37) 0.55 to 250 kW (-01) 45 to 2800 kW (-07) 250 to 3200 kW (-17, -37)
Frequency	50/60 Hz ±5%
Power factor (ACS880-01, -07)	$\cos\phi_1 = 0.98$ (fundamental) $\cos\phi = 0.93$ to 0.95 (total)
Power factor (ACS880-17, -37)	$\cos\phi_1 = 1$ (fundamental)
Efficiency (at nominal power)	98%

Motor connection

Voltage	3-phase output voltage 0 to $U_{N2}/U_{N3}/U_{N5}/U_{N7}$
Frequency	0 to ±500 Hz ^{1) 2)}
Motor control	Direct torque control (DTC)
Torque control:	Torque step rise time: Open loop <5 ms with nominal torque Closed loop <5 ms with nominal torque Non-linearity: Open loop ± 4% with nominal torque Closed loop ± 3% with nominal torque
Speed control:	Static accuracy: Open loop 10% of motor slip Closed loop 0.01% of nominal speed Dynamic accuracy: Open loop 0.3 to 0.4% seconds with 100% torque step Closed loop 0.1 to 0.2% seconds with 100% torque step

Product compliance

- CE
- Low Voltage Directive 2006/95/EC
- Machinery Directive 2006/42/EC
- EMC Directive 2004/108/EC
- Quality assurance system ISO 9001 and Environmental system ISO 14001
- RoHS
- UL, cUL 508A or cUL 508C and CSA C22.2 NO.14-10, C-Tick, EAC ⁴⁾
- Functional safety: STO TÜV Nord certificate
- ATEX-certified Safe Disconnection Function, Ex II (2) GD ⁵⁾
- Marine type approvals for -01

EMC according to EN 61800-3:2004 + A1:2012

Categories C3 and C2 with internal option

Environmental limits

Ambient temperature	Transport -40 to +70 °C Storage -40 to +70 °C Operation (air-cooled) -15 to +55 °C, no frost allowed (-01) 0 to +50 °C, no frost allowed (-07, -17, -37) +40 to 55 °C with derating (-01) ³⁾ +40 to 50 °C with derating of 1%/1 °C (-07,-17,-37)
Cooling method	Air-cooled Dry clean air
Altitude	0 to 1,000 m Without derating 1,000 to 4,000 m With derating of 1%/100 m ⁶⁾
Relative humidity	5 to 95%, no condensation allowed
Degree of protection	IP20 Option (-01) IP21 Standard (-01) IP22 Standard (-07, -17, -37) IP42, IP54 Option (-07, -17, -37) IP55 Option (-01)
Paint color	RAL 9017/9002 (-01), RAL 9017/7035 (-07, -17, -37)
Contamination levels	No conductive dust allowed
Storage	IEC 60721-3-1, Class 1C2 (chemical gases), Class 1S2 (solid particles)
Transportation	IEC 60721-3-2, Class 2C2 (chemical gases), Class 2S2 (solid particles)
Operation	IEC 60721-3-3, Class 3C2 (chemical gases), Class 3S2 (solid particles)
Functional safety	Standard Safe torque off (STO according EN/IEC 61800-5-2) IEC 61508 ed2: SIL 3, IEC 61511: SIL 3, EN/IEC 62061: SIL CL 3, EN ISO 13849-1: PL e With internal safety option safety functions module Safe stop 1 (SS1), safely-limited speed (SLS), safe stop emergency (SSE), safe brake control, (SBC) and safe maximum speed (SMS), prevention of unexpected startup (POUS), Safe direction (SDI), Safe speed monitor (SSM), EN/IEC 61800-5-2, IEC 61508 ed2: SIL 3, IEC 61511: SIL 3, EN/IEC 62061: SIL CL 3, EN ISO 13849-1: PL e TÜV Nord certified Fieldbus communication PROFIsafe over profinet, certified

C = Chemically active substances

S = Mechanically active substances

¹⁾ For higher operational output frequencies please contact your local ABB office

²⁾ Operation above 120 Hz might require type specific derating, please contact your local ABB office

³⁾ Please see pages 12 to 13 for further details

⁴⁾ EAC has replaced GOST R

⁵⁾ Codes +L513/+L514, +Q971 for -07, -17, -37

⁶⁾ Derating reduced by lower than 40 °C ambient temperature

Wall-mounted single drives, ACS880-01

Our wall-mounted drives are designed on ABB's common drives architecture. They are customized to the precise needs of industries such as oil and gas, mining, metals, chemicals, cement, power plants, material handling, pulp and paper, sawmills and marine. They are designed to control a wide range of applications including cranes, extruders, winches, winders, conveyors, mixers, compressors, pumps and fans. The drive comes in nine different frame sizes (R1 to R9) for easy installation and commissioning.

At the heart of the drive is direct torque control (DTC), ABB's premier motor control technology. The extensive range of options include EMC filters, encoder and resolver interfaces, du/dt filters, sine filters, chokes and brake resistors, as well as application specific software. Built-in safety features reduce the need for external safety components. Multiple drives can be daisy-chained for synchronized drive-to-drive communication.

The drives offering includes enclosure classes IP20, IP21 and IP55 for dusty and wet environments. Our offering also covers an option for flange mounting with IP55 back side protection. In flange mounting the control electronics are separated from the cooling airflow for better thermal management.

ABB provides an extensive selection of support documentation for planning including dimension drawings in different formats, EPLAN P8 macros and line apparatus selection tool for selecting external components on the line side and motor side of the drive.

The type approved ACS880-01 marine drive, provides advanced reliability and availability at sea. The drive fulfills marine and offshore requirements and the design and operations have been tested according to marine type approval requirements. ACS880-01 comes with marine type approval from various key classification bodies.

Main features

- Enclosure classes IP20, IP21 and IP55 for different environments
- Compact design for easy installation, commissioning and maintenance
- Integrated safety including safe torque off (STO) as standard and the optional safety functions module, (TÜV Nord certified)
- Supports various motor types including synchronous reluctance motors
- Intuitive control panel with USB connection
- Removable memory unit for easy maintenance
- Drive composer PC tool for commissioning and configuration
- Primary control program - common software used throughout the ACS880 drive series
- Control unit supporting a wide range of fieldbuses, feedback devices and input/output options
- Coated boards as standard
- Controllable cooling fan
- Incoming air temperature measurement for protecting the drive from different temperature related failure mechanisms
- Built-in braking chopper, option for frame sizes R5 to R9
- EMC filter option
- du/dt filter option for motor protection
- Built-in choke
- Supporting optimized cabinet mounting with option (P940, +P944)
- Flange mounting option



ACS880-01,
frame sizes R1 to R9, IP21



ACS880-01,
frame sizes R1, R8 and R5, IP20



ACS880-01,
frame sizes R1, R8 and R5, IP55

Ratings, types and voltages

Wall-mounted drives, ACS880-01

$U_N = 230\text{ V}$ (range 208 to 240 V). The power ratings are valid at nominal voltage 230 V (0.55 to 75 kW).

Nominal ratings			Light-overload use		Heavy-duty use		Noise level	Heat dissipation	Air flow	Type designation	Frame size
I_N A	I_{max} A	P_N kW	I_{Ld} A	P_{Ld} kW	I_{Hd} A	P_{Hd} kW	dBA	W	m ³ /h		
4.6	6.3	0.75	4.4	0.75	3.7	0.55	46	73	44	ACS880-01-04A6-2	R1
6.6	7.8	1.1	6.3	1.1	4.6	0.75	46	94	44	ACS880-01-06A6-2	R1
7.5	11.2	1.5	7.1	1.5	6.6	1.1	46	122	44	ACS880-01-07A5-2	R1
10.6	12.8	2.2	10.1	2.2	7.5	1.5	46	172	44	ACS880-01-10A6-2	R1
16.8	18.0	4.0	16.0	4.0	10.6	2.2	51	232	88	ACS880-01-16A8-2	R2
24.3	28.6	5.5	23.1	5.5	16.8	4	51	337	88	ACS880-01-24A3-2	R2
31.0	41	7.5	29.3	7.5	24.3	5.5	57	457	134	ACS880-01-031A-2	R3
46	64	11	44	11	38	7.5	62	500	200	ACS880-01-046A-2	R4
61	76	15	58	15	45	11	62	630	200	ACS880-01-061A-2	R4
75	104	18.5	71	18.5	61	15	62	680	280	ACS880-01-075A-2	R5
87	122	22	83	22	72	18.5	62	730	280	ACS880-01-087A-2	R5
115	148	30	109	30	87	22	67	840	435	ACS880-01-115A-2	R6
145	178	37	138	37	105	30	67	940	435	ACS880-01-145A-2	R6
170	247	45	162	45	145	37	67	1260	450	ACS880-01-170A-2	R7
206	287	55	196	55	169	45	67	1500	450	ACS880-01-206A-2	R7
274	362	75	260	75	213	55	65	2100	550	ACS880-01-274A-2	R8 ³⁾

$U_N = 400\text{ V}$ (range 380 to 415 V). The power ratings are valid at nominal voltage 400 V (0.55 to 250 kW).

Nominal ratings			Light-overload use		Heavy-duty use		Noise level	Heat dissipation	Air flow	Type designation	Frame size
I_N A	I_{max} A	P_N kW	I_{Ld} A	P_{Ld} kW	I_{Hd} A	P_{Hd} kW	dBA	W	m ³ /h		
2.4	3.1	0.75	2.3	0.75	1.8	0.55	46	30	44	ACS880-01-02A4-3	R1
3.3	4.1	1.1	3.1	1.1	2.4	0.75	46	40	44	ACS880-01-03A3-3	R1
4.0	5.6	1.5	3.8	1.5	3.3	1.1	46	52	44	ACS880-01-04A0-3	R1
5.6	6.8	2.2	5.3	2.2	4.0	1.5	46	73	44	ACS880-01-05A6-3	R1
8	9.5	3.0	7.6	3.0	5.6	2.2	46	94	44	ACS880-01-07A2-3	R1
10	12.2	4.0	9.5	4.0	8	3	46	122	44	ACS880-01-09A4-3	R1
12.9	16.0	5.5	12.0	5.5	10	4	46	172	44	ACS880-01-12A6-3	R1
17	21	7.5	16	7.5	12.6	5.5	51	232	88	ACS880-01-017A-3	R2
25	29	11	24	11	17	7.5	51	337	88	ACS880-01-025A-3	R2
32	42	15	30	15	25	11	57	457	134	ACS880-01-032A-3	R3
38	54	18.5	36	18.5	32	15	57	562	134	ACS880-01-038A-3	R3
45	64	22	43	22	38	18.5	62	667	200	ACS880-01-045A-3	R4
61	76	30	58	30	45	22	62	907	200	ACS880-01-061A-3	R4
72	104	37	68	37	61	30	62	1117	280	ACS880-01-072A-3	R5
87	122	45	83	45	72	37	62	1120	280	ACS880-01-087A-3	R5
105	148	55	100	55	87	45	67	1295	435	ACS880-01-105A-3	R6
145	178	75	138	75	105	55	67	1440	435	ACS880-01-145A-3	R6
169	247	90	161	90	145	75	67	1940	450	ACS880-01-169A-3	R7
206	287	110	196	110	169	90	67	2310	450	ACS880-01-206A-3	R7
246	350	132	234	132	206	110	65	3300	550	ACS880-01-246A-3	R8
293	418	160	278	160	246 ¹⁾	132	65	3900	550	ACS880-01-293A-3	R8 ³⁾
363	498	200	345	200	293	160	68	4800	1150	ACS880-01-363A-3	R9 ⁶⁾
430	545	250	400	200	363 ²⁾	200	68	6000	1150	ACS880-01-430A-3	R9 ⁵⁾

$U_N = 500\text{ V}$ (range 380 to 500 V). The power ratings are valid at nominal voltage 500 V (0.55 to 250 kW).

Nominal ratings			Light-overload use		Heavy-duty use		Noise level	Heat dissipation	Air flow	Type designation	Frame size
I_N A	I_{max} A	P_N kW	I_{Ld} A	P_{Ld} kW	I_{Hd} A	P_{Hd} kW	dBA	W	m ³ /h		
2.1	3.1	0.75	2.0	0.75	1.7	0.55	46	30	44	ACS880-01-02A1-5	R1
3.0	4.1	1.1	2.8	1.1	2.1	0.75	46	40	44	ACS880-01-03A0-5	R1
3.4	5.6	1.5	3.2	1.5	3.0	1.1	46	52	44	ACS880-01-03A4-5	R1
4.8	6.8	2.2	4.6	2.2	3.4	1.5	46	73	44	ACS880-01-04A8-5	R1
5.2	9.5	3.0	4.9	3.0	4.8	2.2	46	94	44	ACS880-01-05A2-5	R1
7.6	12.2	4.0	7.2	4.0	5.2	3	46	122	44	ACS880-01-07A6-5	R1
11.0	16.0	5.5	10.4	5.5	7.6	4	46	172	44	ACS880-01-11A0-5	R1
14	21	7.5	13	7.5	11	5.5	51	232	88	ACS880-01-014A-5	R2
21	29	11	19	11	14	7.5	51	337	88	ACS880-01-021A-5	R2
27	42	15	26	15	21	11	57	457	134	ACS880-01-027A-5	R3
34	54	18.5	32	18.5	27	15	57	562	134	ACS880-01-034A-5	R3
40	64	22	38	22	34	19	62	667	200	ACS880-01-040A-5	R4
52	76	30	49	30	40	22	62	907	200	ACS880-01-052A-5	R4
65	104	37	62	37	52	30	62	1117	280	ACS880-01-065A-5	R5
77	122	45	73	45	65	37	62	1120	280	ACS880-01-077A-5	R5
96	148	55	91	55	77	45	67	1295	435	ACS880-01-096A-5	R6
124	178	75	118	75	96	55	67	1440	435	ACS880-01-124A-5	R6
156	247	90	148	90	124	75	67	1940	450	ACS880-01-156A-5	R7
180	287	110	171	110	156	90	67	2310	450	ACS880-01-180A-5	R7
240	350	132	228	132	180	110	65	3300	550	ACS880-01-240A-5	R8 ⁴⁾
260	418	160	247	160	240 ¹⁾	132	65	3900	550	ACS880-01-260A-5	R8 ³⁾
361	542	200	343	200	302	200	68	4800	1150	ACS880-01-361A-5	R9 ⁶⁾
414	542	250	393	250	361 ²⁾	200	68	6000	1150	ACS880-01-414A-5	R9 ⁵⁾

Ratings, types and voltages

Wall-mounted drives, ACS880-01

$U_N = 690 \text{ V}$ (range 525 to 690 V). The power ratings are valid at nominal voltage 690 V (4 to 250 kW).

Nominal ratings			Light-overload use		Heavy-duty use		Noise level	Heat dissipation	Air flow	Type designation	Frame size
I_N A	I_{max} A	P_N kW	I_{Ld} A	P_{Ld} kW	I_{Hd} A	P_{Hd} kW	dBA	W	m ³ /h		
7.3	12.2	5.5	6.9	5.5	5.6	4	62	217	280	ACS880-01-07A3-7	R5
9.8	18	7.5	9.3	7.5	7.3	5.5	62	284	280	ACS880-01-09A8-7	R5
14.2	22	11	13.5	11	9.8	7.5	62	399	280	ACS880-01-14A2-7	R5
18	29	15	17	15	14.2	11	62	490	280	ACS880-01-018A-7	R5
22	44	18.5	21	18.5	18	15	62	578	280	ACS880-01-022A-7	R5
26	54	22	25	22	22	18.5	62	660	280	ACS880-01-026A-7	R5
35	64	30	33	30	26	22	62	864	280	ACS880-01-035A-7	R5
42	70	37	40	37	35	30	62	998	280	ACS880-01-042A-7	R5
49	71	45	47	45	42	37	62	1120	280	ACS880-01-049A-7	R5
61	104	55	58	55	49	45	67	1295	435	ACS880-01-061A-7	R6
84	124	75	80	75	61	55	67	1440	435	ACS880-01-084A-7	R6
98	168	90	93	90	84	75	67	1940	450	ACS880-01-098A-7	R7
119	198	110	113	110	98	90	67	2310	450	ACS880-01-119A-7	R7
142	250	132	135	132	119	110	65	3300	550	ACS880-01-142A-7	R8
174	274	160	165	160	142	132	65	3900	550	ACS880-01-174A-7	R8 ³⁾
210	384	200	200	200	174	160	68	4800	1150	ACS880-01-210A-7	R9 ⁷⁾
271	411	250	257	250	210	200	68	6000	1150	ACS880-01-271A-7	R9 ⁵⁾

Frame size	Height 1 IP21 (mm)	Height 2 IP20 (mm)	Width (mm)	Depth IP20 (+P940) (mm)	Depth IP20 (+P944) / IP21 (mm)	Weight IP20 (kg)	Weight IP21 (kg)
R1	405	370 ⁸⁾	155	226	226	5.7	6
R2	405	370 ⁸⁾	155	249	249	7.2	8
R3	471	420 ⁸⁾	172	256	261	9.4	10
R4	573	490 ⁸⁾	203	333	274	16.1	18.5
R5	730	596 ⁸⁾	203	333	274	19.3	23
R6	726	569	251	357	357	38.3	45
R7	880	600	284	365	365	47.6	55
R8	963	681	300	386	386	58.6	70
R9	955	680	380	413	413	85.2	98

H1 = Height with cable entry box

H2 = Height without cable entry box

Width and depth with cable entry box

⁸⁾ Comes with main power clamp (Note: only IP20 variant)

Frame size	Height IP55 (mm)	Width IP55 (mm)	Depth IP55 (mm)	Weight IP55 (kg)
R1	450	162	295	6
R2	450	162	315	8
R3	525	180	327	10
R4	576	203	344	18.5
R5	730	203	344	23
R6	726	251	421	45
R7	880	284	423	55
R8	963	300	452	72
R9	955	380	477	100

Nominal ratings

I_N	Rated current available continuously without overloadability at 40 °C.
P_N	Typical motor power in no-overload use.
I_{max}	Maximum output current. Available for 10 seconds at start, then as long as allowed by drive temperature.

Light-overload use

I_{Ld}	Continuous current allowing 110% I_{Ld} for 1 min/5 min at 40 °C.
P_{Ld}	Typical motor power in light-overload use.

Heavy-duty use

I_{Hd}	Continuous current allowing 150% I_{Hd} for 1 min/5 min at 40 °C.
P_{Hd}	Typical motor power in heavy-duty use.

The ratings apply at 40 °C ambient temperature. At higher temperatures (up to 55 °C) the derating is 1%/1 °C.

¹⁾ 130% overload

²⁾ 125% overload

³⁾ For drives with enclosure class IP55 the ratings apply at 40 °C ambient temperature. At higher temperature the derating is from 40 to 45 °C 1%/1 °C and 45 to 55 °C 2.5%/1 °C.

⁴⁾ For drives with enclosure class IP55 the ratings apply at 40 °C ambient temperature. At higher temperature the derating is from 40 to 50 °C 1%/1 °C and 50 to 55 °C 2.5%/1 °C.

⁵⁾ For drives with enclosure class IP55 the maximum ambient temperature is 35 °C.

⁶⁾ For drives with enclosure class IP55 the ratings apply at 40 °C ambient temperature. At higher temperatures the derating is from 40 to 45 °C 1%/1 °C and 45 to 50 °C 2.5%/1 °C and 50 to 55 °C 5%/1 °C.

⁷⁾ For drives with IP55 enclosure class the ratings apply at 40 °C ambient temperature. At higher temperatures the derating is from 40 to 45 °C 3.5%/1 °C. Note: Maximum ambient temperature is 45 °C.

Cabinet-built single drives, ACS880-07

Our cabinet-built single drives are built to order, meeting customer needs despite any technical challenges. Designed on ABB's common drives architecture, this compact drive comes in different sizes for easy assembly and commissioning.

These single drives are customized to the precise needs of industries such as oil and gas, mining, metals, chemicals, cement, power plants, material handling, pulp and paper, woodworking and marine. Typical applications include cranes, extruders, winches, conveyors, mixers, compressors, pumps and fans. The drive configuration contains a rectifier, DC link, inverter, fuses and a main switch, all built into a compact cabinet. The features and options include extended inputs and outputs, fieldbus options, du/dt filtering, EMC filtering and a brake resistor.

Induction motors, synchronous motors and induction servo motors are all supported as standard without the need for additional software. The drive can control the motors in either open loop or closed loop, through its high precision motor control platform, direct torque control (DTC). Built-in safety features reduce the need for external safety components.

Main features

- Compact design for easy cabinet assembly and maintenance
- Main switch and fuses
- Cabling solutions include bottom and top entry and exit
- Enclosure classes IP22, IP42 and IP54 for different environments, with option for air intake through bottom of the cabinet and channeled air outlet on the top of the cabinet
- Integrated safety including safe torque off (STO) as standard and the optional safety functions module, FSO-12 (TÜV Nord certified)
- Supports various motor types including synchronous reluctance motors
- Drive composer PC tool for commissioning and configuration
- Intuitive and easy to operate control panel with USB connection
- Device panel for optional switches and pilot lights
- Primary control program – common software used throughout the ACS880 drive series
- Control unit supporting a wide range of fieldbuses, feedback devices and input/output options
- Removable memory unit for easy maintenance
- Coated boards as standard
- Extensive, programmable digital and analog inputs and outputs
- Line choke
- Long lifetime capacitors
- Cooling fans with speed control or on-off control
- Braking option inside the module or cabinet
- EMC filter option
- du/dt and common mode filter options for motor protection
- Cabinet light and heater option
- Marine construction option



ACS880-07, frame sizes R6 to R8 and R11, IP22



ACS880-07, frame size 1xD8T+2xR8i, IP22

Ratings, types and voltages

Cabinet-built drives, ACS880-07

$U_N = 400\text{ V}$ (range 380 to 415 V). The power ratings are valid at nominal voltage 400 V (45 to 1400 kW).

Nominal ratings			Light-overload use		Heavy-duty use		Noise level	Heat dissipation	Air flow	Type designation	Frame size
I_N A	I_{max} A	P_N kW	I_{Ld} A	P_{Ld} kW	I_{Hd} A	P_{Hd} kW	dBA	W	m ³ /h		

6-pulse diode

105	148	55	100	55	87	45	67	1795	435	ACS880-07-0105A-3	R6
145	178	75	138	75	105	55	67	1940	435	ACS880-07-0145A-3	R6
169	247	90	161	90	145	75	67	2440	450	ACS880-07-0169A-3	R7
206	287	110	196	110	169	90	67	2810	450	ACS880-07-0206A-3	R7
246	350	132	234	132	206	110	65	3800	550	ACS880-07-0246A-3	R8
293	418	160	278	160	246 ¹⁾	132	65	4400	550	ACS880-07-0293A-3	R8
363	498	200	345	200	293	160	68	5300	1150	ACS880-07-0363A-3	R9
430	545	250	400	200	363 ²⁾	200	68	6500	1150	ACS880-07-0430A-3	R9
505	560	250	485	250	361	200	72	5602	1200	ACS880-07-0505A-3	R10
585	730	315	575	315	429	250	72	6409	1200	ACS880-07-0585A-3	R10
650	730	355	634	355	477	250	72	8122	1200	ACS880-07-0650A-3	R10
725	1020	400	715	400	566	315	72	8764	1200	ACS880-07-0725A-3	R11
820	1020	450	810	450	625	355	72	9862	1200	ACS880-07-0820A-3	R11
880	1100	500	865	500	725 ³⁾	400	71	10578	1420	ACS880-07-0880A-3	R11
1140	1482	630	1072	560	787	400	73	18000	4290	ACS880-07-1140A-3	D8T+2×R8i
1250	1630	710	1200	630	935	500	74	21000	5720	ACS880-07-1250A-3	2×D8T+2×R8i
1480	1930	800	1421	800	1107	630	74	25000	5720	ACS880-07-1480A-3	2×D8T+2×R8i
1760	2120	1000	1690	900	1316	710	74	29000	5720	ACS880-07-1760A-3	2×D8T+2×R8i
2210	2880	1200	2122	1200	1653	900	76	37000	8580	ACS880-07-2210A-3	3×D8T+3×R8i
2610	3140	1400	2506	1400	1952	1000	76	44000	8580	ACS880-07-2610A-3	3×D8T+3×R8i

12-pulse diode

990	1287	560	950	500	741	400	73	15000	5720	ACS880-07-0990A-3+A004	2×D7T+2×R8i
1140	1482	630	1094	560	853	450	74	19000	5720	ACS880-07-1140A-3+A004	2×D8T+2×R8i
1250	1630	710	1200	630	935	500	74	21000	5720	ACS880-07-1250A-3+A004	2×D8T+2×R8i
1480	1930	800	1421	800	1107	630	74	25000	5720	ACS880-07-1480A-3+A004	2×D8T+2×R8i
1760	2120	1000	1690	900	1316	710	74	29000	5720	ACS880-07-1760A-3+A004	2×D8T+2×R8i
2210	2880	1200	2122	1200	1653	900	76	35000	10010	ACS880-07-2210A-3+A004	4×D8T+3×R8i
2610	3140	1400	2506	1400	1952	1000	76	44000	10010	ACS880-07-2610A-3+A004	4×D8T+3×R8i

$U_N = 500\text{ V}$ (range 380 to 500 V). The power ratings are valid at nominal voltage 500 V (45 to 1400 kW).

Nominal ratings			Light-overload use		Heavy-duty use		Noise level	Heat dissipation	Air flow	Type designation	Frame size
I_N A	I_{max} A	P_N kW	I_{Ld} A	P_{Ld} kW	I_{Hd} A	P_{Hd} kW	dBA	W	m ³ /h		

6-pulse diode

96	148	55	91	55	77	45	67	1795	435	ACS880-07-0096A-5	R6
124	178	75	118	75	96	55	67	1940	435	ACS880-07-0124A-5	R6
156	247	90	148	90	124	75	67	2440	450	ACS880-07-0156A-5	R7
180	287	110	171	110	156	90	67	2810	450	ACS880-07-0180A-5	R7
240	350	132	228	132	180	110	65	3800	550	ACS880-07-0240A-5	R8
260	418	160	247	160	240 ¹⁾	132	65	4400	550	ACS880-07-0260A-5	R8
361	542	200	343	200	302	200	68	5300	1150	ACS880-07-0361A-5	R9
414	542	250	393	250	361 ²⁾	200	68	6500	1150	ACS880-07-0414A-5	R9
460	560	315	450	315	330	200	72	4403	1200	ACS880-07-0460A-5	R10
503	560	355	483	315	361	250	72	5602	1200	ACS880-07-0503A-5	R10
583	730	400	573	400	414	250	72	6409	1200	ACS880-07-0583A-5	R10
635	730	450	623	450	477	315	72	8122	1200	ACS880-07-0635A-5	R10
715	850	500	705	500	566	400	72	8764	1200	ACS880-07-0715A-5	R11
820	1020	560	807	560	625	450	71	9862	1200	ACS880-07-0820A-5	R11
880	1100	630	857	560	697	500	71	11078	2950	ACS880-07-0880A-5	R11
1070	1391	710	1027	710	800	560	73	18000	4290	ACS880-07-1070A-5	D8T+2×R8i
1320	1716	900	1267	900	987	710	74	22000	5720	ACS880-07-1320A-5	2×D8T+2×R8i
1580	2060	1100	1517	1000	1182	800	74	27000	5720	ACS880-07-1580A-5	2×D8T+2×R8i
1800	2340	1250	1728	1200	1346	900	75	32000	7150	ACS880-07-1800A-5	2×D8T+3×R8i
1980	2574	1400	1901	1300	1481	1000	75	36000	7150	ACS880-07-1980A-5	2×D8T+3×R8i

12-pulse diode

990	1287	710	950	630	741	500	73	16000	5720	ACS880-07-0990A-5+A004	2×D7T+2×R8i
1320	1716	900	1267	900	987	710	74	22000	5720	ACS880-07-1320A-5+A004	2×D8T+2×R8i
1450	1890	1000	1392	900	1085	710	74	25000	5720	ACS880-07-1450A-5+A004	2×D8T+2×R8i
1580	2060	1100	1517	1000	1182	800	74	27000	5720	ACS880-07-1580A-5+A004	2×D8T+2×R8i
1800	2340	1250	1728	1200	1346	900	75	32000	7150	ACS880-07-1800A-5+A004	2×D8T+3×R8i
1980	2574	1400	1901	1300	1481	1000	75	36000	7150	ACS880-07-1980A-5+A004	2×D8T+3×R8i

¹⁾ =130% overload

²⁾ =125% overload

³⁾ =140% overload

Ratings, types and voltages

Cabinet-built drives, ACS880-07

$U_N = 690$ V (range 525 to 690 V). The power ratings are valid at nominal voltage 690 V (45 to 2800 kW).

Nominal ratings			Light-overload use		Heavy-duty use		Noise level	Heat dissipation	Air flow	Type designation	Frame size
I_N A	I_{max} A	P_N kW	I_{Ld} A	P_{Ld} kW	I_{Hd} A	P_{Hd} kW	dBA	W	m ³ /h		

6-pulse diode

61	104	55	58	55	49	45	67	1795	1750	ACS880-07-0061A-7	R6
84	124	75	80	75	61	55	67	1940	1750	ACS880-07-0084A-7	R6
98	168	90	93	90	84	75	67	2440	1750	ACS880-07-0098A-7	R7
119	198	110	113	110	98	90	67	2810	1750	ACS880-07-0119A-7	R7
142	250	132	135	132	119	110	65	3800	1750	ACS880-07-0142A-7	R8
174	274	160	165	160	142	132	65	4400	1750	ACS880-07-0174A-7	R8
210	384	200	200	200	174	160	68	4700	1150	ACS880-07-0210A-7	R9
271	411	250	257	250	210	200	68	5300	1150	ACS880-07-0271A-7	R9
330	480	315	320	315	255	250	72	4903	2950	ACS880-07-0330A-7	R10
370	520	355	360	355	325	315	72	6102	2950	ACS880-07-0370A-7	R10
430	520	400	420	400	360 ⁴⁾	355	72	6909	2950	ACS880-07-0430A-7	R10
425	520	400	415	400	360	355	72	6909	2950	ACS880-07-0425A-7	R11
470	655	450	455	450	415	400	72	8622	2950	ACS880-07-0470A-7	R11
522	655	500	505	500	455	450	72	9264	2950	ACS880-07-0522A-7	R11
590	800	560	571	560	505	500	71	10362	2950	ACS880-07-0590A-7	R11
650	820	630	630	630	571	560	71	11078	3170	ACS880-07-0650A-7	R11
721	820	710	705	630	571 ⁴⁾	560	71	11078	3170	ACS880-07-0721A-7	R11
800	1200	800	768	710	598	560	73	16000	4290	ACS880-07-0800A-7	D8T+2xR8i
900	1350	900	864	800	673	630	74	20000	4290	ACS880-07-0900A-7	D8T+2xR8i
1160	1740	1100	1114	1100	868	800	74	26000	5720	ACS880-07-1160A-7	2xD8T+2xR8i
1450	2175	1400	1392	1250	1085	1000	75	32000	7150	ACS880-07-1450A-7	2xD8T+3xR8i
1650	2475	1600	1584	1500	1234	1200	75	36500	7150	ACS880-07-1650A-7	2xD8T+3xR8i
1950	2925	1900	1872	1800	1459	1400	76	44000	10010	ACS880-07-1950A-7	3xD8T+4xR8i
2300	3450	2200	2208	2000	1720	1600	76	52000	10010	ACS880-07-2300A-7	3xD8T+4xR8i
2600	3900	2500	2496	2400	1945	1900	78	58000	12870	ACS880-07-2600A-7	4xD8T+5xR8i
2860	4290	2800	2746	2600	2139	2000	78	65000	12870	ACS880-07-2860A-7	4xD8T+5xR8i

12-pulse diode

800	1200	800	768	710	598	560	73	16000	5720	ACS880-07-0800A-7+A004	2xD7T+2xR8i
950	1425	900	912	800	711	630	74	20000	5720	ACS880-07-0950A-7+A004	2xD8T+2xR8i
1160	1740	1100	1114	1100	868	800	74	26000	5720	ACS880-07-1160A-7+A004	2xD8T+2xR8i
1450	2175	1400	1392	1250	1085	1000	75	32000	7150	ACS880-07-1450A-7+A004	2xD8T+3xR8i
1650	2475	1600	1584	1500	1234	1200	75	36500	7150	ACS880-07-1650A-7+A004	2xD8T+3xR8i
1950	2925	1900	1872	1800	1459	1400	77	44000	11440	ACS880-07-1950A-7+A004	4xD8T+4xR8i
2300	3450	2200	2208	2000	1720	1600	77	52000	11440	ACS880-07-2300A-7+A004	4xD8T+4xR8i
2600	3900	2500	2496	2400	1945	1900	78	58000	12870	ACS880-07-2600A-7+A004	4xD8T+5xR8i
2860	4290	2800	2746	2400	2139	2000	78	65000	12870	ACS880-07-2860A-7+A004	4xD8T+5xR8i

⁴⁾ =144% overload

Frame size	Height IP22/42 (mm)	Height IP54 (mm)	Width (mm)	Depth (mm)	Weight (kg)
R6	2145	2315	430 ⁵⁾	673	240
R7	2145	2315	430 ⁵⁾	673	250
R8	2145	2315	430 ⁵⁾	673	265
R9	2145	2315	830	698	375
R10	2145	2315	830 ^{5) 6)}	698	530
R11	2145	2315	830 ^{5) 6)}	698	580

⁵⁾ Additional 200 mm if equipped with 1st environment (C2) filter

⁶⁾ Additional 300 mm if equipped with braking chopper

Nominal ratings

I_N	Rated current available continuously without overloadability at 40 °C.
P_N	Typical motor power in no-overload use.
I_{max}	Maximum output current. Available for 10 seconds at start, then as long as allowed by drive temperature.

Light-overload use

I_{Ld}	Continuous current allowing 110% I_{Ld} for 1 min/5 min at 40 °C.
P_{Ld}	Typical motor power in light-overload use.

Heavy-duty use

I_{Hd}	Continuous current allowing 150% I_{Hd} for 1 min/5 min at 40 °C.
P_{Hd}	Typical motor power in heavy-duty use.

The ratings apply at 40 °C ambient temperature. At higher temperatures (up to 50 °C) the derating is 1%/1 °C.
Operation above 150 Hz might require type specific derating.

Frame size	Height IP22/42 (mm)	Height IP54 (mm)	6-pulse width (mm) ¹¹⁾	12-pulse width (mm) ¹¹⁾	Depth (mm) ¹²⁾	Depth top exit (mm)	6-pulse weight (kg)	12-pulse weight (kg)
D8T+2xR8i	2145	2315	1830	–	636	826	1470	–
2xD7T+2xR8i	2145	2315	–	2030 ^{8) 10)}	636	826	–	1710
2xD8T+2xR8i ⁷⁾	2145	2315	2030 ¹⁰⁾	–	636	826	1650	–
2xD8T+2xR8i	2145	2315	2230 ¹⁰⁾	2230 ^{8) 10)}	636	826	1770	1870
2xD8T+3xR8i	2145	2315	2430 ¹⁰⁾	2430 ^{8) 10)}	636	826	1920	2020
3xD8T+3xR8i	2145	2315	2630 ¹⁰⁾	–	636	826	2230	–
3xD8T+4xR8i	2145	2315	3030 ¹⁰⁾	–	636	826	2590	–
4xD8T+3xR8i	2145	2315	–	3030 ^{9) 10)}	636	826	–	2600
4xD8T+4xR8i	2145	2315	–	3430 ^{9) 10)}	636	826	–	2960
4xD8T+5xR8i	2145	2315	3630 ¹⁰⁾	3630 ^{9) 10)}	636	826	3030	3110

⁷⁾ ACS880-07-1160A-7

⁸⁾ Additional 200 mm if equipped with earthing switch

⁹⁾ Additional 600 mm if equipped with line contactor, earthing switch or air circuit breaker

¹⁰⁾ Additional 200 mm if top entry

¹¹⁾ If UL variant the width may differ

¹²⁾ Top exit with backpack for n x R8i, additional depth is 190 mm

Cabinet-built regenerative single drives, ACS880-17

This single drive is a compact and complete regenerative drive solutions, with everything needed for a regenerative operation. The ACS880-17 captures and utilizes energy which results in cost savings for the user. With regenerative functionality, the braking energy of the motor is returned back to the drive and distributed forward to the supply network. This way, the braking energy is not wasted as heat. In comparison with other braking methods, such as mechanical and resistor braking, the ACS880-17 brings much more energy savings.

The ACS880-17 is compatible with a broad range of industries including automotive, food and beverage, oil and gas, chemical, mining and metals. The drive is suitable for applications such as centrifuges, test benches conveyors, winches, elevators, pumps and fans.

High performance drives

The drive features direct torque control (DTC) as standard, enabling fast transition between motoring and generating mode in applications such as test benches and elevators. The drives active supply unit is able to boost output voltage, which guarantees full motor voltage even when the supply voltage is below nominal. The ACS880-17 reaches unity power factor.

Clear energy savings

Handling of waste heat may be a problem if the braking power is significant. The ACS880-17 does not need external braking devices, which makes drive installation simple as less need for cabinet space is required.

Extensive range of features

In line with other ACS880 cabinet-built drives, the ACS880-17 adapts to a wide variety of standardized configurations and different application requirements. The ACS880-17 comes with a significant amount of features and accessories as built-in options.

Main features

- Compact design for easy cabinet assembly and maintenance. Enclosure classes IP22, IP42 and IP54 for different environments, with option for air intake through bottom of the cabinet and channeled air outlet on the top of the cabinet
- LCL line filter built inside
- Main switch and fuses
- Cabling solutions include bottom and top entry and exit
- Integrated safety including safe torque off (STO) as standard and the optional safety functions module (TÜV Nord certificate)
- Supports various motor types including synchronous reluctance motors
- Drive composer PC tool for commissioning and configuration
- Intuitive and easy to operate control panel with USB connection
- Device panel for optional switches and pilot lights
- Primary control program – common software used throughout the ACS880 drive series
- Control unit supporting a wide range of fieldbuses, feedback devices and input/output options
- Removable memory unit for easy maintenance
- Coated boards as standard
- Extensive, programmable digital and analog inputs and outputs
- Long lifetime capacitors
- Cooling fans with speed control or on-off control
- EMC filter as standard
- du/dt and common mode filter options for motor protection
- Cabinet light and heater option
- Marine construction option



ACS880-17 cabinet-built regenerative drive

Ratings, types and voltages

Cabinet-built drives, ACS880-17

$U_N = 400\text{ V}$ (range 380 to 415 V). The power ratings are valid at nominal voltage 400 V (160 to 1200 kW).

Nominal ratings			Light-overload use		Heavy-duty use		Noise level	Heat dissipation	Air flow	Type designation	Frame size
I_N A	I_{max} A	P_N kW	I_{Ld} A	P_{Ld} kW	I_{Hd} A	P_{Hd} kW	dBA	W	m ³ /h		
450	590	250	432	200	337	160	75	14000	2860	ACS880-17-0450A-3	1xR8i+1xR8i
620	810	355	595	315	464	250	75	18000	2860	ACS880-17-0620A-3	1xR8i+1xR8i
870	1140	500	835	450	651	355	75	27000	2860	ACS880-17-0870A-3	1xR8i+1xR8i
1110	1450	630	1066	560	830	450	77	31000	5720	ACS880-17-1110A-3	2xR8i+2xR8i
1210	1580	710	1162	630	905	500	77	34000	5720	ACS880-17-1210A-3	2xR8i+2xR8i
1430	1860	800	1373	710	1070	560	77	38000	5720	ACS880-17-1430A-3	2xR8i+2xR8i
1700	2210	1000	1632	900	1272	710	77	51000	5720	ACS880-17-1700A-3	2xR8i+2xR8i
2060	2680	1200	1978	1100	1541	800	78	61000	8580	ACS880-17-2060A-3	3xR8i+3xR8i
2530	3290	1400	2429	1200	1892	1000	78	76000	8580	ACS880-17-2530A-3	3xR8i+3xR8i

$U_N = 500\text{ V}$ (range 380 to 500 V). The power ratings are valid at nominal voltage 500 V (200 to 1500 kW).

Nominal ratings			Light-overload use		Heavy-duty use		Noise level	Heat dissipation	Air flow	Type designation	Frame size
I_N A	I_{max} A	P_N kW	I_{Ld} A	P_{Ld} kW	I_{Hd} A	P_{Hd} kW	dBA	W	m ³ /h		
420	550	250	403	250	314	200	75	13000	2860	ACS880-17-0420A-5	1xR8i+1xR8i
570	750	400	547	355	426	250	75	17000	2860	ACS880-17-0570A-5	1xR8i+1xR8i
780	1020	560	749	500	583	400	75	25000	2860	ACS880-17-0780A-5	1xR8i+1xR8i
1010	1320	710	970	630	755	500	77	31000	5720	ACS880-17-1010A-5	2xR8i+2xR8i
1110	1450	800	1066	710	830	560	77	32000	5720	ACS880-17-1110A-5	2xR8i+2xR8i
1530	1990	1100	1469	1000	1144	800	77	46000	5720	ACS880-17-1530A-5	2xR8i+2xR8i
1980	2580	1400	1901	1300	1481	1000	78	59000	8580	ACS880-17-1980A-5	3xR8i+3xR8i
2270	2960	1600	2179	1500	1698	1200	78	69000	8580	ACS880-17-2270A-5	3xR8i+3xR8i

$U_N = 690\text{ V}$ (range 525 to 690 V). The power ratings are valid at nominal voltage 690 V (200 to 3000 kW).

Nominal ratings			Light-overload use		Heavy-duty use		Noise level	Heat dissipation	Air flow	Type designation	Frame size
I_N A	I_{max} A	P_N kW	I_{Ld} A	P_{Ld} kW	I_{Hd} A	P_{Hd} kW	dBA	W	m ³ /h		
320	480	315	307	250	239	200	75	16000	2860	ACS880-17-0320A-7	1xR8i+1xR8i
390	590	355	374	355	292	250	75	19000	2860	ACS880-17-0390A-7	1xR8i+1xR8i
580	870	560	557	500	434	400	75	26000	2860	ACS880-17-0580A-7	1xR8i+1xR8i
660	990	630	634	560	494	450	77	30000	5720	ACS880-17-0660A-7	2xR8i+2xR8i
770	1160	710	739	710	576	560	77	34000	5720	ACS880-17-0770A-7	2xR8i+2xR8i
950	1430	900	912	800	711	710	77	40000	5720	ACS880-17-0950A-7	2xR8i+2xR8i
1130	1700	1100	1085	1000	845	800	77	48000	5720	ACS880-17-1130A-7	2xR8i+2xR8i
1450	2180	1400	1392	1300	1085	1000	78	63000	8580	ACS880-17-1450A-7	3xR8i+3xR8i
1680	2520	1600	1613	1500	1257	1200	78	74000	8580	ACS880-17-1680A-7	3xR8i+3xR8i
1950	2930	1900	1872	1800	1459	1400	79	84000	11440	ACS880-17-1950A-7	4xR8i+4xR8i
2230	3350	2200	2141	2000	1668	1600	79	95000	11440	ACS880-17-2230A-7	4xR8i+4xR8i
2770	4160	2700	2659	2600	2072	2000	79	119000	14300	ACS880-17-2770A-7	5xR8i+5xR8i
3310	4970	3200	3178	3000	2476	2400	79	142000	17160	ACS880-17-3310A-7	6xR8i+5xR8i

Frame size	Height IP21/22/42 mm	Height IP54 mm	Width mm	Depth mm	Depth top exit mm	Weight kg
1xR8i+1xR8i	2145	2315	1230	636	826	1180
2xR8i+2xR8i	2145	2315	2430 ²⁾	636	826	2090
2xR8i+2xR8i	2145	2315	2220	636	826	1970
3xR8i+3xR8i	2145	2315	3230	636	826	2930
3xR8i+3xR8i ¹⁾	2145	2315	3230	636	826	2730
4xR8i+4xR8i	2145	2315	3830	636	826	3700
6xR8i+5xR8i	2145	2315	5330	636	826	4980
6xR8i+5xR8i ³⁾	2145	2315	5030	636	826	4830

¹⁾ ACS880-17-1450A-7, -1680A-7

²⁾ ACS880-17-1210A-3, -1430A-3, -1700A-3, -1530A-5

³⁾ ACS880-17-1450A-7, -1680A-7

Nominal ratings	
I_N	Rated current available continuously without overloadability at 40 °C.
P_N	Typical motor power in no-overload use.
I_{max}	Maximum output current. Available for 10 seconds at start, then as long as allowed by drive temperature.
Light-overload use	
I_{Ld}	Continuous current allowing 110% I_{Ld} for 1 min/5 min at 40 °C.
P_{Ld}	Typical motor power in light-overload use.
Heavy-duty use	
I_{Hd}	Continuous current allowing 150% I_{Hd} for 1 min/5 min at 40 °C.
P_{Hd}	Typical motor power in heavy-duty use.

The ratings apply at 40 °C ambient temperature. At higher temperatures (up to 50 °C) the derating is 1%/1 °C.
Operation above 150 Hz might require type specific derating.

Cabinet-built low harmonic single drives, ACS880-37

This single drive creates less harmonics compared to drives that offer standard diode supply solutions. The ACS880-37 produces exceptionally low harmonic content in the drives input. This is achieved without external filters or multi-pulse transformers. By managing and controlling harmonics, the ACS880-37 reaches unity power factor. The active supply unit in the drive is able to boost output voltage, which guarantees full motor voltage even when the supply voltage is below nominal.

The ACS880-37 is compatible with a broad range of industries including oil and gas, chemical, mining, water and wastewater, cement and metals. The drive is suitable for applications such as pumps and fans, extruders, conveyors and compressors.

Improved harmonic performance

When compared to multi-pulse transformer solutions, the ACS800-37 does not require a dedicated transformer. For this reason, the cabinet-built low harmonic drive is simpler in terms of cabling arrangements and requires less floor space. Harmonic performance is also better compared with 12- and 18-pulse solutions, handling online imbalance or other shortcomings in the supply network. Passive or active external filtering devices are avoided with the ACS800-37, making the solution compact and simple.

Extensive range of features

In line with other ACS880 cabinet-built drives, the ACS880-37 adapts to a wide variety of standardized configurations and different application requirements. The ACS880-37 comes with a significant amount of features and accessories as built-in options.

Main features

- Compact design for easy cabinet assembly and maintenance. Enclosure classes IP22, IP42 and IP54 for different environments, with option for air intake through bottom of the cabinet and channeled air outlet on the top of the cabinet
- LCL line filter built inside
- Main switch and fuses
- Cabling solutions include bottom and top entry and exit
- Integrated safety including safe torque off (STO) as standard and the optional safety functions module (TÜV Nord certificate)
- Supports various motor types including synchronous reluctance motors
- Drive composer PC tool for commissioning and configuration
- Intuitive and easy to operate control panel with USB connection
- Device panel for optional switches and pilot lights
- Primary control program – common software used throughout the ACS880 drive series
- Control unit supporting a wide range of fieldbuses, feedback devices and input/output options
- Removable memory unit for easy maintenance
- Coated boards as standard
- Extensive, programmable digital and analog inputs and outputs
- Long lifetime capacitors
- Cooling fans with speed control or on-off control
- EMC filter as standard
- du/dt and common mode filter options for motor protection
- Cabinet light and heater option
- Marine construction option



ACS880-37 cabinet-built low harmonic drive

Ratings, types and voltages

Cabinet-built drives, ACS880-37

$U_N = 400\text{ V}$ (range 380 to 415 V). The power ratings are valid at nominal voltage 400 V (160 to 1200 kW).

Nominal ratings			Light-overload use		Heavy-duty use		Noise level	Heat dissipation	Air flow	Type designation	Frame size
I_N A	I_{max} A	P_N kW	I_{Ld} A	P_{Ld} kW	I_{Hd} A	P_{Hd} kW	dBA	W	m ³ /h		
450	590	250	432	200	337	160	75	14000	2860	ACS880-37-0450A-3	1xR8i+1xR8i
620	810	355	595	315	464	250	75	18000	2860	ACS880-37-0620A-3	1xR8i+1xR8i
870	1140	500	835	450	651	355	75	27000	2860	ACS880-37-0870A-3	1xR8i+1xR8i
1110	1450	630	1066	560	830	450	77	31000	5720	ACS880-37-1110A-3	2xR8i+2xR8i
1210	1580	710	1162	630	905	500	77	34000	5720	ACS880-37-1210A-3	2xR8i+2xR8i
1430	1860	800	1373	710	1070	560	77	38000	5720	ACS880-37-1430A-3	2xR8i+2xR8i
1700	2210	1000	1632	900	1272	710	77	51000	5720	ACS880-37-1700A-3	2xR8i+2xR8i
2060	2680	1200	1978	1100	1541	800	78	61000	8580	ACS880-37-2060A-3	3xR8i+3xR8i
2530	3290	1400	2429	1200	1892	1000	78	76000	8580	ACS880-37-2530A-3	3xR8i+3xR8i

$U_N = 500\text{ V}$ (range 380 to 500 V). The power ratings are valid at nominal voltage 500 V (200 to 1500 kW).

Nominal ratings			Light-overload use		Heavy-duty use		Noise level	Heat dissipation	Air flow	Type designation	Frame size
I_N A	I_{max} A	P_N kW	I_{Ld} A	P_{Ld} kW	I_{Hd} A	P_{Hd} kW	dBA	W	m ³ /h		
420	550	250	403	250	314	200	75	13000	2860	ACS880-37-0420A-5	1xR8i+1xR8i
570	750	400	547	355	426	250	75	17000	2860	ACS880-37-0570A-5	1xR8i+1xR8i
780	1020	560	749	500	583	400	75	25000	2860	ACS880-37-0780A-5	1xR8i+1xR8i
1010	1320	710	970	630	755	500	77	31000	5720	ACS880-37-1010A-5	2xR8i+2xR8i
1110	1450	800	1066	710	830	560	77	32000	5720	ACS880-37-1110A-5	2xR8i+2xR8i
1530	1990	1100	1469	1000	1144	800	77	46000	5720	ACS880-37-1530A-5	2xR8i+2xR8i
1980	2580	1400	1901	1300	1481	1000	78	59000	8580	ACS880-37-1980A-5	3xR8i+3xR8i
2270	2960	1600	2179	1500	1698	1200	78	69000	8580	ACS880-37-2270A-5	3xR8i+3xR8i

$U_N = 690\text{ V}$ (range 525 to 690 V). The power ratings are valid at nominal voltage 690 V (200 to 3000 kW).

Nominal ratings			Light-overload use		Heavy-duty use		Noise level	Heat dissipation	Air flow	Type designation	Frame size
I_N A	I_{max} A	P_N kW	I_{Ld} A	P_{Ld} kW	I_{Hd} A	P_{Hd} kW	dBA	W	m ³ /h		
320	480	315	307	250	239	200	75	16000	2860	ACS880-37-0320A-7	1xR8i+1xR8i
390	590	355	374	355	292	250	75	19000	2860	ACS880-37-0390A-7	1xR8i+1xR8i
580	870	560	557	500	434	400	75	26000	2860	ACS880-37-0580A-7	1xR8i+1xR8i
660	990	630	634	560	494	450	77	30000	5720	ACS880-37-0660A-7	2xR8i+2xR8i
770	1160	710	739	710	576	560	77	34000	5720	ACS880-37-0770A-7	2xR8i+2xR8i
950	1430	900	912	800	711	710	77	40000	5720	ACS880-37-0950A-7	2xR8i+2xR8i
1130	1700	1100	1085	1000	845	800	77	48000	5720	ACS880-37-1130A-7	2xR8i+2xR8i
1450	2180	1400	1392	1300	1085	1000	78	63000	8580	ACS880-37-1450A-7	3xR8i+3xR8i
1680	2520	1600	1613	1500	1257	1200	78	74000	8580	ACS880-37-1680A-7	3xR8i+3xR8i
1950	2930	1900	1872	1800	1459	1400	79	84000	11440	ACS880-37-1950A-7	4xR8i+4xR8i
2230	3350	2200	2141	2000	1668	1600	79	95000	11440	ACS880-37-2230A-7	4xR8i+4xR8i
2770	4160	2700	2659	2600	2072	2000	79	119000	14300	ACS880-37-2770A-7	5xR8i+5xR8i
3310	4970	3200	3178	3000	2476	2400	79	142000	17160	ACS880-37-3310A-7	6xR8i+5xR8i

Frame size	Height IP21/22/42 mm	Height IP54 mm	Width mm	Depth mm	Depth top exit mm	Weight kg
1xR8i+1xR8i	2145	2315	1230	636	826	1180
2xR8i+2xR8i	2145	2315	2430 ²⁾	636	826	2090
2xR8i+2xR8i	2145	2315	2220	636	826	1970
3xR8i+3xR8i	2145	2315	3230	636	826	2930
3xR8i+3xR8i ¹⁾	2145	2315	3230	636	826	2730
4xR8i+4xR8i	2145	2315	3830	636	826	2290
6xR8i+5xR8i	2145	2315	5330	636	826	4980
6xR8i+5xR8i ³⁾	2145	2315	5030	636	826	4830

¹⁾ ACS880-17-1450A-7, -1680A-7

²⁾ ACS880-37-1210A-3, -1430A-3, -1700A-3, -1530A-5

³⁾ ACS880-17-1450A-7, -1680A-7

Nominal ratings

I_N Rated current available continuously without overloadability at 40 °C.

P_N Typical motor power in no-overload use.

I_{max} Maximum output current. Available for 10 seconds at start, then as long as allowed by drive temperature.

Light-overload use

I_{Ld} Continuous current allowing 110% I_{Ld} for 1 min/5 min at 40 °C.

P_{Ld} Typical motor power in light-overload use.

Heavy-duty use

I_{Hd} Continuous current allowing 150% I_{Hd} for 1 min/5 min at 40 °C.

P_{Hd} Typical motor power in heavy-duty use.

The ratings apply at 40 °C ambient temperature. At higher temperatures (up to 50 °C) the derating is 1%/1 °C.

Operation above 150 Hz might require type specific derating.

Standard interface and extensions for comprehensive connectivity

The ACS880 single drives offers a wide range of standard interfaces. In addition the drive has three option slots that can be used for extensions including fieldbus adapter modules,

input/output extension modules, feedback modules and a safety functions module.

Control connections	Description
2 analog inputs (XAI)	Current input: -20 to 20 mA, R_{in} : 100 ohm Voltage input: -10 to 10 V, R_{in} > 200 kohm Resolution: 11 bit + sign bit
2 analog outputs (XAO)	0 to 20 mA, R_{load} < 500 ohm Frequency range: 0 to 300 Hz Resolution: 11 bit + sign bit
6 digital inputs (XDI)	Input type: NPN/PNP (DI1 to DI5), NPN (DI6) DI6 (XDI:6) can alternatively be used as an input for a PTC thermistor.
Digital input interlock (DIIL)	Input type: NPN/PNP
2 digital inputs/outputs (XDIO)	As input: 24 V logic levels: "0" < 5 V, "1" > 15 V R_{in} : 2.0 kohm Filtering: 0.25 ms As output: Total output current from 24 V DC is limited to 200 mA Can be set as pulse train input and output
3 relay outputs (XRO1, XRO2, XRO3)	250 V AC/30 V DC, 2 A
Safe torque off (XSTO)	For the drive to start, both connections must be closed
Drive-to-drive link (XD2D)	Physical layer: EIA-485
Built-in Modbus	EIA-485
Assistant control panel/ PC tool connection	Connector: RJ-45



Control unit ZCU

Example of a typical single drives input/output connection diagram. Variations maybe possible (please see HW manual for more information).

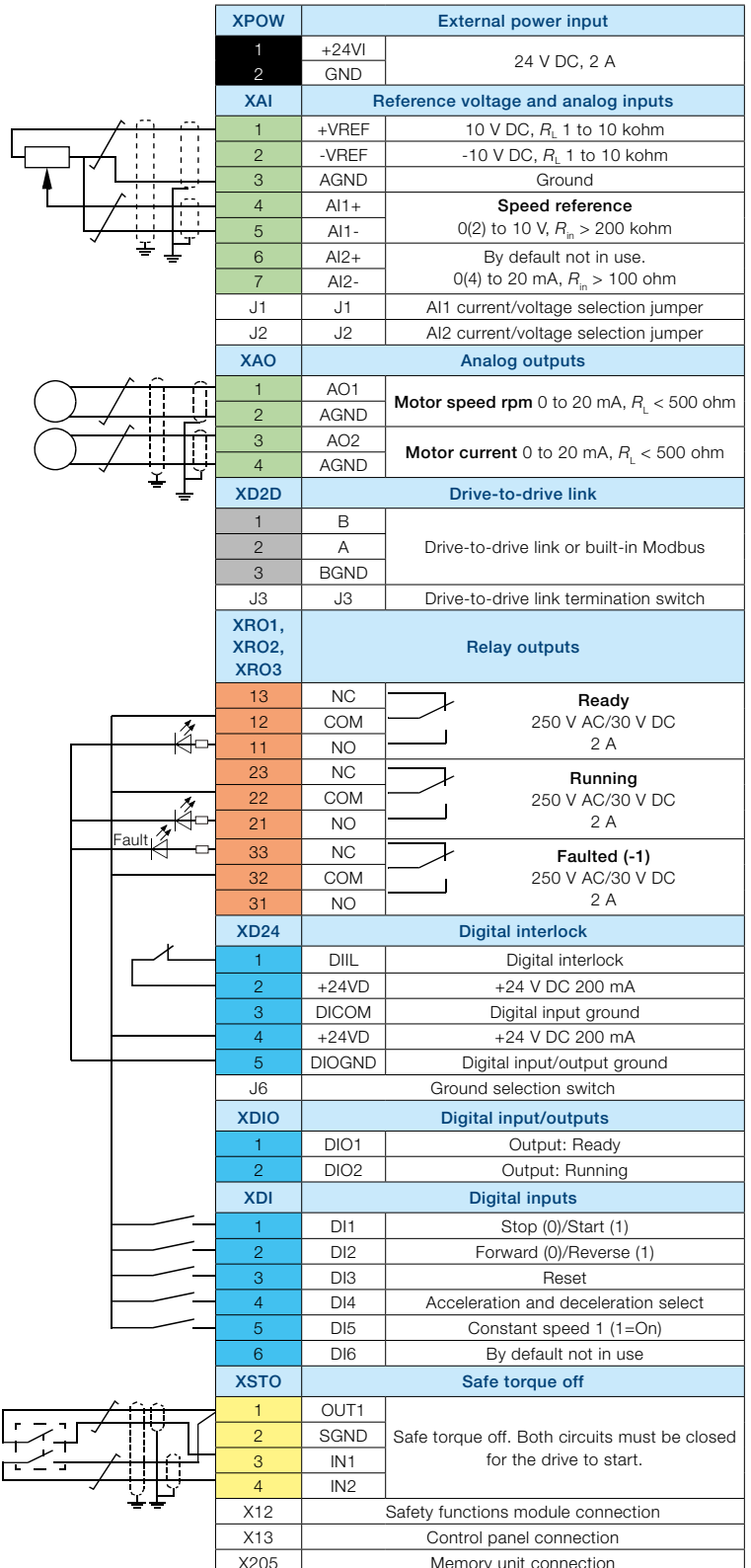

Standard software for scalable control and functionality

The same software, the primary control program, is used across the whole ACS880 series. Features such as built-in pre-programmed application macros save time during configuration and drive commissioning. The application macros help set parameters for various functions including:

- Basic setup for input/output control and fieldbus control
- Hand/auto control for local and remote operation
- PID control for closed loop processes
- Sequential control for repetitive cycles
- Torque control
- Four user sets, for saving multiple drive configurations

Direct torque control (DTC)

The drives are equipped with direct torque control (DTC), ABB's signature motor control platform which supports motors such as induction motors, permanent magnet motors and servo motors and the new synchronous reluctance motor. DTC helps control the motor from standstill to maximum torque and speed without the necessity of encoders or position sensors. DTC allows high overloadability, gives high starting torque and reduces stress on mechanics.

Energy efficiency information

The drives come with built-in energy efficiency information that helps the user fine-tune processes to ensure optimum energy use. The energy optimizer mode ensures the maximum torque per ampere, reducing energy drawn from the supply. The load profile feature collects drive values with three loggers: two amplitude loggers and one peak value logger. Calculators provide essential energy efficiency information: used and saved electrical energy, CO₂ reduction and money saved.

Additional software features include:

- Access levels
- Adaptive programming
- Automatic reset
- Automatic start
- Constant speeds
- Critical speeds and frequencies
- DC hold
- DC magnetizing
- Diagnostics
- Drive-to-drive link for master-follower control
- Flux braking
- Jogging
- Maintenance timer and counters
- Mechanical brake control
- Motor potentiometer
- Output phase order selection, switches rotation direction of the motor
- Oscillation damping
- Power loss ride-through
- Process PID control with trim function
- Programmable and pre-programmed protection functions
- Programmable inputs and outputs
- Scalar control with IR compensation
- Speed controller with auto tuning
- Startup assistants
- User adjustable load supervision/limitation
- User selectable acceleration and deceleration ramps
- Variable slope

Removable memory unit

The removable memory unit stores the software that includes user settings, parameter settings and motor data. Situated on the control unit, the memory unit can easily be removed for maintenance, update or replacement purposes. This common type of memory unit is used throughout the ACS880 series.



Application control programs



Our application control programs are developed by working closely with our customers over many years. This results in application programs that include the lessons learned from many customers, and that are designed to give you the flexibility to adapt the programs to your specific needs. These programs enhance application usability and lower energy consumption. They increase safe operation of the applications and reduce the need for a PLC. Other benefits include protection of machinery and optimization of application productivity. The programs also optimize time usage and lower operational costs.

The ACS880 application control programs come with adaptive programming features. This makes fine tuning of the ready-made application control program functionalities easy. Additionally, we understand that you may need to use different configurations in your process. That's why each of our control programs comes with the ability to configure up to four different configurations, or "user sets." The ACS880 drives offer integrated safety with safe torque off (STO) functionality as standard. The optional safety functions module comes with several safety functions including safe brake control (SBC).

Control program for cranes

This control program is dedicated for industrial, harbor, tower and marine deck cranes. It is possible to control crane

movements in hoist and trolley and travel motions using the same software. The control program comes with integrated mechanical brake control to assure safe opening and closing of the mechanical disc or drum brakes. Standalone and master-follower functionality is supported along with synchro control of multimotors. The synchro control for common operation of the load functionality makes it possible to lift and lower loads, such as containers, in a smooth and balanced way during transportation. The load speed control function maximizes the hoist speed for the given load and ensures that there is sufficient motor torque in the field weakening area. This minimizes operation time and optimizes crane capacity. Fieldbus and conventional I/O control is supported. The antisway function is designed for indoor cranes to prevent unnecessary swaying of the load.

Control program for winder

This control program makes sure that the unwinding and winding of a roll of web material, such as textile, plastic and paper is performed optimally. The control program observes the diameter of rolls and tension of the web material and makes sure that the drives controlling different parts of the winder are in sync. Based on the feedback from the dancer or tension measurement of the web, the speed or torque of the drive is adjusted appropriately. The result is a straightforward, cost-effective solution in web handling. Another feature is the mechanics ID run function that calculates automatically the inertia and friction of the roll. This speeds up the commissioning of the drive.

Application control programs



Control program for artificial oil lifting

This control program increases oil production for PCP (progressive cavity pumps), ESP (electro submersible pumps) or rod pumps. The program does not require any feedback encoder to work, which saves costs and increases reliability. The software also reduces stress on the complete pump system when optimizing fluid production. Backspin functionality is especially suitable for PCP and ESP pumps, which minimizes failure and makes oil pumping safe. Various startup ramp functions are also available. The sensorless control function (pump off control) helps to optimize oil pumping productivity by keeping the energy usage on a predetermined level. The efficiency of PCP pumps is significantly increased when using ACS880 drives together with SynRM motors.

Control program for centrifuge/decanter

This control program is designed to perform practical programmable sequences for conventional centrifuges. The program optimizes the separation of solids from the liquids in centrifuges, separators or decanter centrifuges. The speed difference of the decanter bowl and the scroll in the decanter centrifuge is controlled by the drive-to-drive functionality available in ACS880 drives.

Control program for cooling tower

This program is used in ACS880 drives to control high-torque and slow-speed synchronous RPM-AC permanent magnet motors in cooling tower applications. The control program is the basis for a drive-motor package where the cooling tower direct drive motor (CTDD) and the ACS880 drive is installed directly to the fans without any need for gearboxes, drive shafts or couplings. This provides high torque that is required for cooling tower applications without additional drivetrain components. The result is energy savings, reduced maintenance risk and costs, and direct-on-load startup current peaks. The control program for cooling tower is easy to commission and use. The ACS880 drives offer a streamlined parameter set that is focused on the typical cooling tower direct drive configurations where only necessary parameters are visible. Other cooling tower features in the drive include trickle current for keeping the motor warm and dry, a de-icing function to prevent ice build-up on the fan blades and an anti-windmill function to prevent rotation of the fan during standby.

Designed to control virtually any type of AC motor

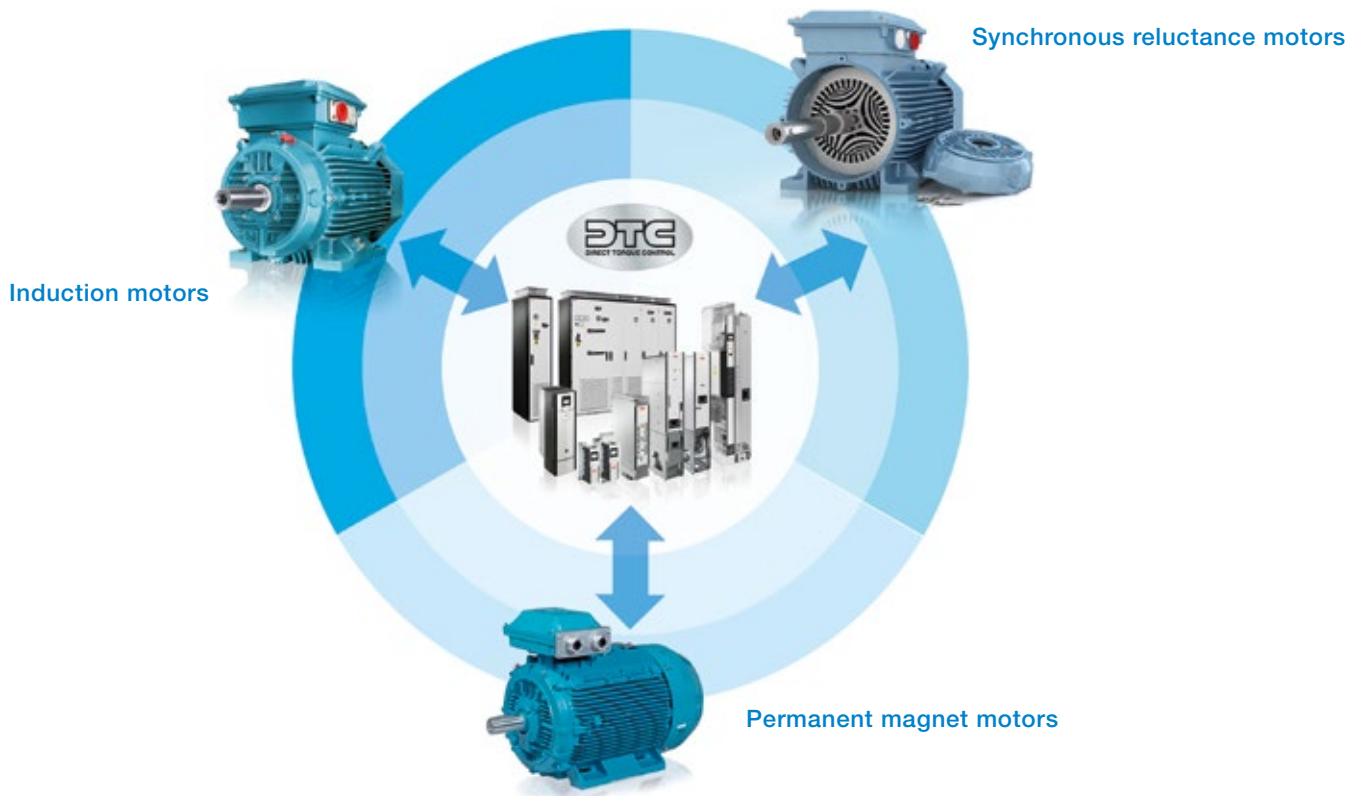

Our ACS880 drives control virtually any type of AC motor including induction, permanent magnet, servo and synchronous reluctance motors. Motor control is optimized with direct torque control (DTC), ABB's premium motor control, built-in as a standard feature in our ACS880 drives. Our robust industrial drives ensure an energy efficient and reliable motor controller with significant cost savings for the user.

Direct torque control (DTC) for optimal control of motors

To ensure optimal control of an AC motor, our ACS880 drives offer direct torque control (DTC) as a built-in standard feature. In majority of applications, the DTC reduces the need for an expensive speed feedback encoder. Direct torque control provides fast reaction to load changes in the motor shaft as well as reference changes on speed or torque made by the user. It makes the motor run optimally which lowers energy consumption and wear of the application.

ACS880 and induction motors form a reliable combination

Induction motors are used throughout the industry in several types of industry applications which demand robust and high enclosure motor and drive solutions. The ACS880 drives fit perfectly together with this type of motor, used in a wide range of industrial environments. The drives fit into environments that require high degree of protection and offer narrow facilities. ACS880 drives come with DTC as standard, which ensures high speed accuracy.

Because ABB Ex motors and ACS880 have been type tested as a package, they are a safe and reliable choice to be used in explosive environments.

ACS880 and permanent magnet motors for smooth operation

Permanent magnet technology is often used for improved motor characteristics such as energy efficiency, compactness and control performance. This technology is suitable eg for low speed control industry applications, as in some cases they eliminate the need to use gear boxes. Actual characteristics between different permanent magnet motors can vary considerably. ACS880 drives with DTC control ABB and most other permanent magnet motors without speed or rotor position sensors.

ACS880 and IE4 synchronous reluctance motors for a package with high efficiency

Combining the ACS880's control technology with our synchronous reluctance (SynRM) motors provides an IE4 motor and drive package that gives you great energy savings benefits. The key is in the rotor design. The synchronous reluctance rotor replaces the traditional induction rotor and requires no permanent magnets. ABB has tested our SynRM motor and drive packages and produced manufacturer's statements providing verified system (drive and motor) efficiency.

Intuitive human-machine interface

The assistant control panel features intuitive use and easy navigation. High resolution display enables visual guidance. The panel saves on commissioning and learning time by means of different assistants, making the drive simple to set up and use.

It is possible to organize parameters in different ways and store essential parameters for different configurations for any specialized application needed. The menus and messages can be customized for specific terminology so that each application can be set up and configured to its optimum performance. This makes the drive easier to use with information that is familiar to users. With the panel's text editor, users can also add information, customize text and label the drive. Powerful backup and restore functions are supported as well as different language versions. The help key provides context sensitive guidance. Faults or warnings can be resolved quickly since the help key provides troubleshooting instructions.

One control panel can be connected to several drives simultaneously using the panel network feature. The user can also select the drive to operate in the panel network. The PC tool can be easily connected to the drive through the USB connector on the control panel. There are also control panel mounting platforms, DPMP-01 and DPMP-02, available for cabinet door mounting with IP55 or IP65 protection class.



PC tool for easy startup and maintenance

The Drive composer PC tool offers fast and harmonized setup, commissioning and monitoring for the whole drives portfolio. The free version of the tool provides startup and maintenance capabilities, while the professional version provides additional features such as custom parameter windows, control diagrams of the drive's configuration and safety settings.

The Drive composer tool is connected to the drive using an Ethernet connection or through the USB connection on the assistant control panel. All drive information such as parameter loggers, faults, backups and event lists are gathered into a support diagnostics file with a single mouse click. This provides faster fault tracking, shortens downtime and minimizes operational and maintenance costs.

signals from several drives in a PC tool network. Full backup and restore functions are also included. Safety settings and adaptive programming programs can be configured with Drive composer pro.

Drive composer pro

Drive composer pro provides basic functionality, including parameter settings, downloading and uploading files and search parameters. Advanced features such as graphical control diagrams and various displays are also available. The control diagrams save users from browsing long lists of parameters and help to set the drive's logic quickly and easily. The tool has fast monitoring capabilities of multiple



Integrated safety simplifies configuration

Integrated safety reduces the need for external safety components, simplifying configuration and reducing installation space. The safety functionality is a built-in feature of the ACS880, with safe torque off (STO) as standard. Additional safety functions can be commissioned with the optional and compact safety functions module. ACS880 drives offer encoderless safety. The drives' functional safety is designed in accordance with EN/IEC 61800-5-2 and complies with the requirements of the European Union Machinery Directive 2006/42/EC.

Safe torque off as standard

Safe torque off (STO) is used to prevent unexpected startup and in stopping-related functions, enabling safe machine maintenance and operation. With safe torque off activated, the drive will not provide a rotational field. This prevents the motor from generating torque on the shaft. This function corresponds to an uncontrolled stop in accordance with stop category 0 of EN 60204-1.

The safety functions module

The easy to connect and configure safety functions module (FSO-12 and -21) offers a wide range of safety functions and a self diagnostic function that meets current safety requirements and standards, all in one compact module. Compared to using external safety components, the safety functions module comes with the supported functions seamlessly integrated with the drive functionality, reducing the implementation of safety function connections and configuration. Installation of the module results in less need for cabling and provides a cost-effective solution.

Commissioning and configuration of the safety functions module is done with the Drive composer pro PC tool. Larger safety systems can be built using PROFIsafe over Profinet connection between a safety PLC (such as AC500-S) and the

ACS880 drive. The connection is achieved using the FENA-21 fieldbus adapter module and the safety functions module.

The safety functions module can also be ordered as a spare part kit and installed afterwards to the drive. The kit includes most common assembly accessories for ACS880 drives.

The module supports the following safety functions (which achieve up to SIL 3 or PL e (Cat. 3) safety level):

- **Safe stop 1 (SS1)** brings the machine to a stop (STO) using a monitored deceleration ramp. It is typically used in applications where the machinery motion needs to be brought to a stop (stop category 1) in a controlled way before switching over to the no-torque state.
- **Safe stop emergency (SSE)** can be configured to, upon request, either activate STO instantly (category 0 stop), or first initiate motor deceleration and then, once the motor has stopped, activate the STO (category 1 stop).
- **Safe brake control (SBC)** provides a safe output for controlling the motor's external (mechanical) brakes, together with STO.
- **Safely-limited speed (SLS)** ensures that the specified speed limit of the motor is not exceeded. This allows machine interaction to be performed at slow speed without stopping the drive. The safety function module comes with four individual SLS settings for speed monitoring.
- **Safe maximum speed (SMS)** monitors that the speed of the motor does not exceed the configured speed limit.
- **Prevention of unexpected startup (POUS)** ensures that the machine remains stopped when people are in a danger area.
- **Safe direction (SDI)** ensures that rotation is allowed only to the selected direction. Available only with FSO-21 and FSE-31.
- **Safe speed monitor (SSM)** provides information that speed is within the configured limits. Available only with FSO-21

Safety functions module

Option	Ordering code
FSO-12	+Q973
FSO-21+FSE-31	+Q972+L521 ¹⁾

1) For availability please check with your local ABB



ACS880 drive with FSO-12

ACS880 cabinet-built drive with FSO-12

Drive application programming based on IEC standard 61131-3

Automation Builder, ABB's new software suite for automation engineering, makes programming of industry devices such as drives, PLC's, robots and human machine interfaces (HMI) easy using one Integrated engineering suite. The Automation Builder is used both for engineering individual industry devices and for putting together entire automation projects. It is based on a widely used software environment that fulfills many different requirements of industrial automation projects, according to the IEC standard 61131-3. As a single tool, the Automation Builder reduces time typically needed for system configuration and programming. It also reduces the need for installing and maintaining separate programs simultaneously. Automation Builder enables the possibility to do online diagnostic checking of multiple tasks performed by different industrial devices such as ACS880 drives.

Drive application programming

Automation Builder makes it possible for system integrators and machine builders to integrate their desired functionality and know-how directly into ACS880 drives. This is possible as ACS880 drives come with programming capability embedded inside the drive. Designing an application program in the drive makes the end user application run more efficiently, even without a separate programmable controller. It also brings higher end-product quality and requires less need for installation space and wiring.

Automation Builder lets you extend the standard functionality of parameter functions for ACS880 drives. This makes the ACS880 drives very flexible to meet exact requirements set for end user applications. The library management functionality in Automation Builder shortens engineering time as reuse of existing program code is possible. Additional features include the ability to select and use one of five different programming languages, effective program debugging and user password protection.

Integrated engineering suite for operating several industry components together

Using the Drive manager tool embedded in Automation Builder together with ABB's AC500 PLC gives the user online connection to all drives in a fieldbus network. This speeds up commissioning and makes diagnostic of the entire automation system easy. Automation Builder saves all the configuration data of industry devices, including drive parameter settings, and program code to the same project archive. This makes engineering work more consistent and manageable.

The drive application programming license should be ordered together with the drive.

Drive application programmability

Option	Option code
License key ¹⁾	+N8010

¹⁾ The Automation Builder tools must be ordered separately. For further information please contact your local ABB.



Automation Builder

One engineering tool to control all industry devices
 System configuration and diagnostic
 IEC programming
 Common project data handling

Flexible connectivity to automation networks

Our fieldbus adapter modules enable communication between drives, systems, devices and software. Our industrial drives are compatible with a wide range of fieldbus protocols.

The plug-in fieldbus adapter module can easily be mounted inside the drive. Other benefits include reduced wiring costs when compared with traditional input/output connections. Fieldbus systems are also less complex than conventional systems, resulting in less overall maintenance.

Multiple fieldbus connections for flexible control

ACS880 supports two fieldbus connections simultaneously. The user has flexibility of choice for control modes by being able to select one protocol for control and one for monitoring. Also redundant fieldbus connection is possible.

Drive monitoring

A set of drive parameters and/or actual signals, such as torque, speed, current, etc., can be selected for cyclic data transfer, providing fast data access.

Drive diagnostics

Accurate and reliable diagnostic information can be obtained through the alarm, limit and fault words.

Drive parameter handling

The Ethernet fieldbus adapter module allows users to build an Ethernet network for drive monitoring and diagnostic and parameter handling purposes.

Cabling

Substituting the large amount of conventional drive control cabling and wiring with a single cable reduces costs and increases system reliability and flexibility.

Design

The use of fieldbus control reduces engineering time at installation due to the modular structure of the hardware and software and the simplicity of the connections to the drives.

Commissioning and assembly

The modular machine configuration allows pre-commissioning of single machine sections and provides easy and fast assembly of the complete installation.

Universal communication with ABB fieldbus adapters

The ACS880 supports the following fieldbus protocols:

Fieldbus adapter modules

Option	Option code	Fieldbus protocol
FPBA-01	+K454	PROFIBUS DP, DPV0/DPV1
FCAN-01	+K457	CANopen®
FDNA-01	+K451	DeviceNet™
FENA-11	+K473	1 port EtherNet/IP™, Modbus TCP, PROFINET IO
FENA-21	+K475	2 port EtherNet/IP™, Modbus TCP, PROFINET IO, PROFIsafe ¹⁾
FECA-01	+K469	EtherCAT®
FSCA-01	+K458	Modbus RTU
FEPL-02	+K470	PowerLink
FCNA-01	+K462	ControlNet™

¹⁾ For the PROFIsafe to work the PROFINET fieldbus adapter module (FENA-21) and the safety functions module are required.



ACS880 drive with fieldbus adapters and feedback interface module

Input/output extension modules for increased connectivity

Standard input and output can be extended by using optional analog and digital input/output extension modules. The modules are easily installed in the extension slots located on the control unit.

Analog and digital input/output extension modules

Option	Option code	Connections
FIO-01	+L501	4×DI/O, 2×RO
FIO-11	+L500	3×AI (mA/V), 1×AO (mA), 2×DI/O
FAIO-01	+L525	2×AI(mA/V), 2×AO(mA)

Speed feedback interfaces for precise process control

ACS880 drives can be connected to various feedback devices, such as HTL pulse encoder, TTL pulse encoder, absolute encoder and resolver. The optional feedback module is installed in the option slot on the drive. It is possible to use two feedback modules at the same time, either of the same type or different type.

Feedback interface modules

Option	Option code	Connections
FEN-01	+L517	2 inputs (TTL pulse encoder), 1 output
FEN-11	+L518	2 inputs (SinCos absolute, TTL pulse encoder), 1 output
FEN-21	+L516	2 inputs (Resolver, TTL pulse encoder), 1 output
FEN-31	+L502	1 input (HTL pulse encoder), 1 output

I/O option extension adapter

For additional I/O option slots the FEA-03 is suitable for this use. An analog and digital input/output extension and speed feedback interface can be installed on the FEA-03. Two extension modules can be installed on each I/O extension slot. The connection to the control unit is via an fiber optic link and the adapter can be mounted on an DIN rail (35 x 7.5 mm).

I/O extension adapter

Option	Option code	Connections
FEA-03	+L515	2×F-type option extension slots

DDCS communication option modules

The FDCO-0X optical DDCS communication options are add-on modules on the ACS880 industrial drives control unit. The modules include connectors for two fiber optic DDCS channels. The FDCO-0X modules make it possible to perform master-follower and AC800 M communication.

Option	Option code	Connections
FDCO-01	+L503	Optical DDCS (10 Mbd/10 Mbd)
FDCO-02	+L508	Optical DDCS (5 Mbd/10 Mbd)

Remote monitoring access worldwide

The remote monitoring tool, NETA-21, gives easy access to the drive via the Internet or local Ethernet network. NETA-21 comes with a built-in web server. Being compatible with standard web browsers, it ensures easy access to a web-based user interface. Through the interface the user can configure drive parameters, monitor drive log data, and follow up load levels, run time, energy consumption, I/O data and bearing temperature of the motor connected to the drive.

The user can access the remote monitoring tool web page using 3G modem from anywhere with a standard PC, tablet or a mobile phone. The remote monitoring tool helps to reduce cost when personnel are able to monitor or perform maintenance for unmanned or manned applications in a range of industries. It is also very useful when more than one user wants to access the drive from several locations.

Enhanced monitoring functions

The remote monitoring tool supports process and drive data logging. Values of process variables or drives actual

values can be logged to NETA-21's SD memory card which is situated in the remote monitoring tool or sent forward to a centralized database. NETA-21 does not need an external database as the remote monitoring tool is able to store valuable data of the drive during its entire lifetime.

Unmanned monitoring of processes or devices is ensured by the built-in alarm functions that notify maintenance personnel if a safety level is reached. Alarm history with true time stamps are stored internally to the memory card as well as technical data, which is provided by the drive for troubleshooting purposes. True time stamps are also used with drives that do not have a real time clock as standard for ensuring events of all connected drives. Remote monitoring is also possible through AC500 PLC by using Drive Manager functionality.



NETA-21

EMC – electromagnetic compatibility

Each ACS880 model can be equipped with a built-in filter to reduce high frequency emissions.

EMC standards

The EMC product standard (EN 61800-3 (2004)) covers the specific EMC requirements stated for drives (tested with motor and cable) within the EU. EMC standards such as EN 55011 or EN 61000-6-3/4 are applicable to industrial and domestic equipment and systems including components inside the drive. Drive units complying with the requirements of EN 61800-3 are compliant with comparable categories in EN 55011 and EN 61000-6-3/4, but not necessarily vice versa. EN 55011 and EN 61000-6-3/4 do not specify cable length or require a motor to be connected as a load. The emission limits are comparable to EMC standards according to the table below.

1st environment versus 2nd environment

1st environment includes domestic premises. It also includes establishments directly connected without an intermediate transformer to a low voltage power supply network that supplies buildings used for domestic purposes.

2nd environment includes all establishments other than those directly connected to a low voltage power supply network that supplies buildings used for domestic purposes.

EMC standards

EMC according to EN 61800-3:2004 + A1:2012 product standard	EN 61800-3 product standard	EN 55011, product family standard for industrial, scientific and medical (ISM) equipment	EN 61000-6-4, generic emission standard for industrial environments	EN 61000-6-3, generic emission standard for residential, commercial and light-industrial environment
1 st environment, unrestricted distribution	Category C1	Group 1, Class B	Not applicable	Applicable
1 st environment, restricted distribution	Category C2	Group 1, Class A	Applicable	Not applicable
2 nd environment, unrestricted distribution	Category C3	Group 2, Class A	Not applicable	Not applicable
2 nd environment, restricted distribution	Category C4	Not applicable	Not applicable	Not applicable

Selecting an EMC filter

The following table gives the correct filter selection.

Type	Voltage	Frame sizes	1 st environment, restricted distribution, C2, grounded network (TN) Option code	2 nd environment, C3, grounded network (TN) Option code	2 nd environment, C3, ungrounded network (IT) Option code	2 nd environment, C3, grounded/ungrounded network (TN/IT) Option code
ACS880-01	380 to 500 V	R1 to R9	+E202	+E200	+E201 (R6 to R9 frame size)	–
ACS880-01	690 V	R5 to R9	–	+E200 (R5 to R9 frame size)	+E201 (R7 to R9 frame size)	–
ACS880-07	380 to 690 V	R6 to R11	+E202 (not for 690 V)	+E200	+E201	+E210 (R10 to R11)
ACS880-07	380 to 690 V	n×R8i	+E202 (not for 690 V only for 0990A, 1070A and 1140A)	–	–	As standard
ACS880-17	380 to 690 V	n×R8i	+E202 (not for 690 V. Only for 1×R8i)	–	–	As standard
ACS880-37	380 to 690 V	n×R8i	+E202 (not for 690 V. Only for 1×R8i)	–	–	As standard

Sine filters, ACS880-01

Together with a sine filter, ACS880 drives offer smooth motor operation. The sine filter suppresses high frequency components of the motors output voltage, creating almost a sinusoidal voltage wave form for the motor. The filter offers optimized LC design that takes into account switching frequency, voltage drop and filtering characteristics.

The ACS880 inverter and sine filter solution can be used together with a variety of requirements for products and components:

- For motors which don't have adequate insulation for the drives duty
- Where the total motor cable length is long as a result of a number of parallel motors
- For step-up applications eg where medium voltage motor needs to be driven
- For submersible pumps with long motor cables eg in the oil industry
- When the motor noise needs to be reduced
- When there are industry specific requirements for peak voltage level and voltage rise time

I _N A	P _N kW	Noise level dB *	Heat dissi- pation kW *	Type designation	Filter size	Degree of protection	Filter								Frame size
							Width IP00 mm	Width IP21 mm	Depth IP00 mm	Depth IP21 mm	Height IP00 mm	Height IP21 mm	Weight IP00 kg	Weight IP21 kg	

U_N = 400 V (range 380 to 415 V). The power ratings are valid at nominal voltage 400 V.

2.3	0.8	72	60	ACS880-01-02A4-3	B84143V0004R229	IP00/IP21	235	384	95	152	200	246	4.5	14.4	R1
3.1	1.1	72	60	ACS880-01-03A3-3	B84143V0004R229	IP00/IP21	235	384	95	152	200	246	4.5	14.4	R1
3.8	1.5	72	60	ACS880-01-04A0-3	B84143V0004R229	IP00/IP21	235	384	95	152	200	246	4.5	14.4	R1
5.3	2.2	72	100	ACS880-01-05A6-3	B84143V0006R229	IP00/IP21	235	384	95	152	200	246	4.5	14.4	R1
7.2	3	72	90	ACS880-01-07A2-3	B84143V0011R229	IP00/IP21	235	384	110	152	200	246	5.2	14.4	R1
9.4	4	72	90	ACS880-01-09A4-3	B84143V0011R229	IP00/IP21	235	384	110	152	200	246	5.2	14.4	R1
12.1	5.5	72	80	ACS880-01-12A6-3	B84143V0016R229	IP00/IP21	275	420	122	200	235	290	7.9	24.4	R1
16	7.5	75	140	ACS880-01-017A-3	B84143V0025R229	IP00/IP21	355	500	120	200	285	360	12.1	36	R2
24	11	75	140	ACS880-01-025A-3	B84143V0025R229	IP00/IP21	355	500	120	200	285	360	12.1	36	R2
31	15	75	160	ACS880-01-032A-3	B84143V0033R229	IP00/IP21	355	500	120	200	285	360	12.1	36	R3
37	18.5	78	220	ACS880-01-038A-3	B84143V0050R229	IP00/IP21	400	650	140	350	360	460	20.2	90.3	R3
43	22	78	220	ACS880-01-045A-3	B84143V0050R229	IP00/IP21	400	650	140	350	360	460	20.2	90.3	R4
60	30	78	250	ACS880-01-061A-3	B84143V0066R229	IP00/IP21	400	650	147	350	360	460	21.2	90.3	R4
64	30	79	310	ACS880-01-072A-3	B84143V0075R229	IP00/IP21	400	650	173	350	360	460	24.9	90.3	R5
77	37	79	400	ACS880-01-087A-3	B84143V0095R229	IP00/IP21	440	700	164	350	500	580	36.1	132	R5
91	45	80	600	ACS880-01-105A-3	B84143V0130R230	IP00/IP21	560	850	300	480	420	500	73.3	192	R6
126	55	80	550	ACS880-01-145A-3	B84143V0162R229	IP00/IP21	500	730	300	400	380	430	50.3	129.9	R6
153	75	80	550	ACS880-01-169A-3	B84143V0162R229	IP00/IP21	500	730	300	400	380	430	50.3	129.9	R7
187	90	80	900	ACS880-01-206A-3	B84143V0230R229	IP00/IP21	570	850	285	480	430	500	69.9	192	R7
209	110	80	900	ACS880-01-246A-3	B84143V0230R229	IP00/IP21	570	850	285	480	430	500	69.9	192	R8
249	132	80	1570	ACS880-01-293A-3	B84143V0390R229	IP00/IP21	555	850	328	550	580	610	105.6	268.4	R8
297	160	80	1570	ACS880-01-363A-3	B84143V0390R229	IP00/IP21	555	850	328	550	580	610	105.6	268.4	R9
352	160	80	1570	ACS880-01-430A-3	B84143V0390R229	IP00/IP21	555	850	328	550	580	610	105.6	268.4	R9

U_N = 500 V (range 380 to 500 V). The power ratings are valid at nominal voltage 500 V.

1.9	0.8	72	60	ACS880-01-02A1-5	B84143V0004R229	IP00/IP21	235	384	95	152	200	246	4.5	14.4	R1
2.8	1.1	72	60	ACS880-01-03A0-5	B84143V0004R229	IP00/IP21	235	384	95	152	200	246	4.5	14.4	R1
3.1	1.5	72	60	ACS880-01-03A4-5	B84143V0004R229	IP00/IP21	235	384	95	152	200	246	4.5	14.4	R1
4.4	2.2	72	100	ACS880-01-04A8-5	B84143V0006R229	IP00/IP21	235	384	95	152	200	246	4.5	14.4	R1
4.8	3	72	100	ACS880-01-05A2-5	B84143V0006R229	IP00/IP21	235	384	95	152	200	246	4.5	14.4	R1
7	4	72	90	ACS880-01-07A6-5	B84143V0011R229	IP00/IP21	235	384	110	152	200	246	5.2	14.4	R1
10.2	5.5	72	90	ACS880-01-11A0-5	B84143V0011R229	IP00/IP21	235	384	110	152	200	246	5.2	14.4	R1
13	7.5	70	80	ACS880-01-014A-5	B84143V0016R229	IP00/IP21	275	420	122	200	235	290	7.9	24.4	R2
20	11	75	140	ACS880-01-021A-5	B84143V0025R229	IP00/IP21	355	500	120	200	285	360	12.1	36	R2
25	15	75	160	ACS880-01-027A-5	B84143V0033R229	IP00/IP21	355	500	120	200	285	360	12.1	36	R3
32	18.5	78	220	ACS880-01-034A-5	B84143V0050R229	IP00/IP21	400	650	140	350	360	460	17.4	90.3	R3
35	22	78	220	ACS880-01-040A-5	B84143V0050R229	IP00/IP21	400	650	140	350	360	460	20.2	90.3	R4
49	30	78	250	ACS880-01-052A-5	B84143V0066R229	IP00/IP21	400	650	147	350	360	460	21.2	90.3	R4
60	37	78	250	ACS880-01-065A-5	B84143V0066R229	IP00/IP21	400	650	147	350	360	460	21.2	90.3	R5
62	37	78	310	ACS880-01-077A-5	B84143V0075R229	IP00/IP21	400	650	173	350	360	460	24.9	132	R5
80	55	80	630	ACS880-01-096A-5	B84143V0130R230	IP00/IP21	565	850	300	480	420	500	73.3	192	R6
104	55	80	630	ACS880-01-124A-5	B84143V0130R230	IP00/IP21	565	850	300	480	420	500	73.3	192	R6
140	90	80	550	ACS880-01-156A-5	B84143V0162R229	IP00/IP21	500	730	300	400	380	430	50.3	129.9	R7
162	110	80	550	ACS880-01-180A-5	B84143V0162R229	IP00/IP21	500	730	300	400	380	430	50.3	129.9	R7
205	132	80	900	ACS880-01-240A-5	B84143V0230R229	IP00/IP21	570	850	285	480	430	500	69.9	192	R8
221	132	80	900	ACS880-01-260A-5	B84143V0230R229	IP00/IP21	570	850	285	480	430	500	69.9	192	R8
289	200	80	1570	ACS880-01-361A-5	B84143V0390R229	IP00/IP21	555	850	328	550	580	610	105.6	268.4	R9
332	200	80	1570	ACS880-01-414A-5	B84143V0390R229	IP00/IP21	555	850	328	550	580	610	105.6	268.4	R9

Sine filters, ACS880-01

I_N	P_N	Noise level dB *	Heat dissipation kW *	Type designation	Filter size	Degree of protection	Filter								Frame size
							Width IP00 mm	Width IP21 mm	Depth IP00 mm	Depth IP21 mm	Height IP00 mm	Height IP21 mm	Weight IP00 kg	Weight IP21 kg	
$U_N = 690\text{ V}$ (range 525 to 690 V). The power ratings are valid at nominal voltage 690 V.															
7.3	5.5	72	90	ACS880-01-07A3-7	B84143V0010R230	IP00/IP21	380	500	110	200	290	360	12.1	36	R5
9.3	7.5	72	90	ACS880-01-09A8-7	B84143V0010R230	IP00/IP21	380	500	110	200	290	360	12.1	36	R5
13.5	11	72	130	ACS880-01-14A2-7	B84143V0018R230	IP00/IP21	380	500	121	200	290	360	13.3	36	R5
17.1	15	72	130	ACS880-01-018A-7	B84143V0018R230	IP00/IP21	380	500	121	200	290	360	13.3	36	R5
21	18.5	72	160	ACS880-01-022A-7	B84143V0026R230	IP00/IP21	380	500	141	200	290	360	15.5	68	R5
25	22	72	160	ACS880-01-026A-7	B84143V0026R230	IP00/IP21	380	500	141	200	290	360	15.5	68	R5
33	30	75	250	ACS880-01-035A-7	B84143V0040R230	IP00/IP21	440	650	147	350	355	430	23	90.3	R5
40	37	75	250	ACS880-01-042A-7	B84143V0040R230	IP00/IP21	440	650	147	350	355	430	23	90.3	R5
48	45	78	290	ACS880-01-049A-7	B84143V0056R230	IP00/IP21	440	650	162	350	355	430	25.3	90.3	R5
56	55	78	290	ACS880-01-061A-7	B84143V0056R230	IP00/IP21	440	600	162	350	355	430	25.3	90.3	R6
78	75	79	610	ACS880-01-084A-7	B84143V0092R230	IP00/IP21	500	700	193	350	490	580	47.3	132	R6
92	90	79	610	ACS880-01-098A-7	B84143V0092R230	IP00/IP21	500	700	193	350	490	580	47.3	132	R7
112	110	80	630	ACS880-01-119A-7	B84143V0130R230	IP00/IP21	565	850	300	480	420	500	73.3	192	R7
112	110	80	630	ACS880-01-142A-7	B84143V0130R230	IP00/IP21	560	850	230	480	569	500	73.3	192	R8
138	132	80	930	ACS880-01-174A-7	B84143V0207R230	IP00/IP21	560	850	279	550	570	610	89.1	268.4	R8
161	132	80	930	ACS880-01-210A-7	B84143V0207R230	IP00/IP21	560	850	279	550	570	610	89.1	268.4	R9
208	200	80	930	ACS880-01-271A-7	B84143V0207R230	IP00/IP21	560	850	279	550	570	610	89.1	268.4	R9

Nominal ratings

I_N Rated current of the drive-filter combination available continuously without overload at 40 °C.

Typical ratings

P_N Typical motor power

* Note: Noise level is a combined value for the drive and the filter. Heat dissipation is a combined value for the drive and the filter.
For further information please contact your local ABB.

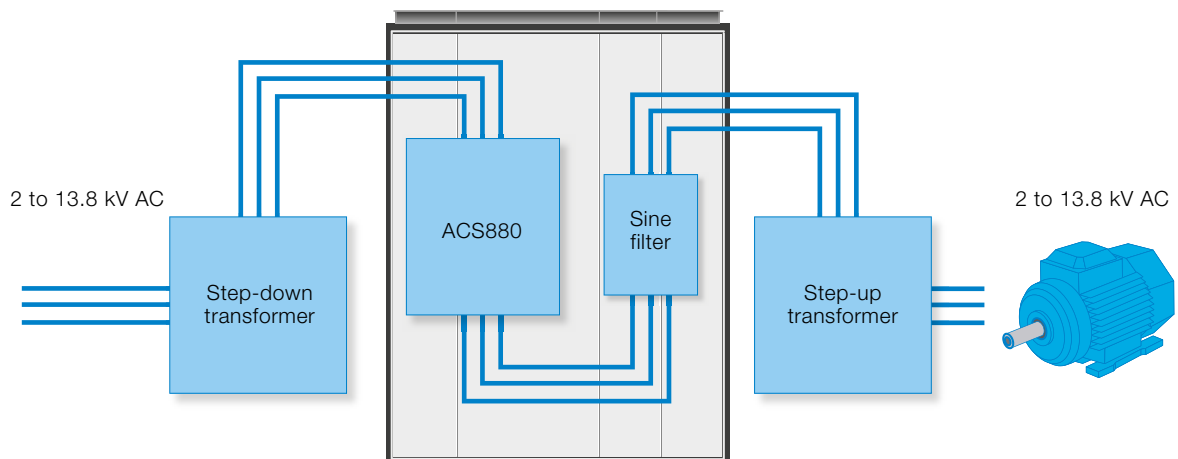

For step-up applications eg where medium voltage motor needs to be driven

Sine filters, ACS880-07

I_N A	P_N kW	Noise level dB	Heat dissipation kW	Air flow m ³ /h	Type designation	Filter size	Degree of protection	Filter				Frame size
								Height mm	Width mm	Depth mm	Weight mm	

$U_N = 400$ V (range 380 to 415 V). The power ratings are valid at nominal voltage 400 V.

6-pulse diode

505	250	80	3	2000	ACS880-07-505A-3	NSIN900-6	IP22	2130	1030	646	700	R10
585	315	80	3.4	2000	ACS880-07-585A-3	NSIN900-6	IP22	2130	1030	646	700	R10
650	355	80	3.8	2000	ACS880-07-650A-3	NSIN900-6	IP22	2130	1030	646	700	R10
725	400	80	4.1	2000	ACS880-07-725A-3	NSIN900-6	IP22	2130	1030	646	700	R11
820	450	80	4.7	2000	ACS880-07-820A-3	NSIN900-6	IP22	2130	1030	646	700	R11
880	500	80	5	2000	ACS880-07-880A-3	NSIN900-6	IP22	2130	1030	646	700	R11
1140	630	81	7	2000	ACS880-07-1140A-3	NSIN-1380-6 ¹⁾	IP22	2145	1000	636	750	D8T+2xR8i
1250	710	82	10	4000	ACS880-07-1250A-3	2xNSIN-0900-6 ¹⁾	IP22	2145	2000	636	1100	2xD8T+2xR8i
1480	800	82	10	4000	ACS880-07-1480A-3	2xNSIN-0900-6 ¹⁾	IP22	2145	2000	636	1100	2xD8T+2xR8i
1760	1000	82	14	4000	ACS880-07-1760A-3	2xNSIN-1380-6 ¹⁾	IP22	2145	2000	636	1500	2xD8T+2xR8i
2210	1200	82	14	4000	ACS880-07-2210A-3	2xNSIN-1380-6 ¹⁾	IP22	2145	2000	636	1500	3xD8T+3xR8i
2610	1400	83	14	6000	ACS880-07-2610A-3	3xNSIN-1380-6 ¹⁾	IP22	2145	3000	636	2250	3xD8T+3xR8i

12-pulse diode

990	560	81	7	2000	ACS880-07-0990A-3+A004	NSIN-1380-6 ¹⁾	IP22	2145	1000	636	750	2xD7T+2xR8i
1140	630	81	7	2000	ACS880-07-1140A-3+A004	NSIN-1380-6 ¹⁾	IP22	2145	1000	636	750	2xD8T+2xR8i
1250	710	82	10	4000	ACS880-07-1250A-3+A004	2xNSIN-0900-6 ¹⁾	IP22	2145	2000	636	1100	2xD8T+2xR8i
1480	800	82	10	4000	ACS880-07-1480A-3+A004	2xNSIN-0900-6 ¹⁾	IP22	2145	2000	636	1100	2xD8T+2xR8i
1760	1000	82	14	4000	ACS880-07-1760A-3+A004	2xNSIN-1380-6 ¹⁾	IP22	2145	2000	636	1500	2xD8T+2xR8i
2210	1200	82	14	4000	ACS880-07-2210A-3+A004	2xNSIN-1380-6 ¹⁾	IP22	2145	2000	636	1500	4xD8T+3xR8i
2610	1400	83	21	6000	ACS880-07-2610A-3+A004	3xNSIN-1380-6 ¹⁾	IP22	2145	2000	636	1500	4xD8T+3xR8i

$U_N = 500$ V (range 380 to 500 V). The power ratings are valid at nominal voltage 500 V.

6-pulse diode

460	315	80	3.3	2000	ACS880-07-460A-5	NSIN900-6	IP22	2130	1030	646	700	R10
503	355	80	3.6	2000	ACS880-07-503A-5	NSIN900-6	IP22	2130	1030	646	700	R10
583	400	80	3.9	2000	ACS880-07-583A-5	NSIN900-6	IP22	2130	1030	646	700	R10
635	450	80	4.3	2000	ACS880-07-635A-5	NSIN900-6	IP22	2130	1030	646	700	R10
715	500	80	4.9	2000	ACS880-07-715A-5	NSIN900-6	IP22	2130	1030	646	700	R11
820	560	80	5.6	2000	ACS880-07-820A-5	NSIN900-6	IP22	2130	1030	646	700	R11
880	630	80	5.6	2000	ACS880-07-0880A-5	NSIN900-6	IP22	2130	1030	646	700	R11
1070	710	81	8	2000	ACS880-07-1070A-5	NSIN-1380-6 ¹⁾	IP22	2145	1000	636	750	D8T+2xR8i
1320	900	81	12	2000	ACS880-07-1320A-5	2xNSIN-0900-6 ¹⁾	IP22	2145	2000	636	750	2xD8T+2xR8i
1450	1000	82	12	4000	ACS880-07-1450A-5	2xNSIN-0900-6 ¹⁾	IP22	2145	2000	636	1100	2xD8T+2xR8i
1580	1100	82	16	4000	ACS880-07-1580A-5	2xNSIN-1380-6 ¹⁾	IP22	2145	2000	636	1500	2xD8T+2xR8i
1800	1250	82	16	4000	ACS880-07-1800A-5	2xNSIN-1380-6 ¹⁾	IP22	2145	2000	636	1500	2xD8T+3xR8i
1980	1400	83	16	6000	ACS880-07-1980A-5	2xNSIN-1380-6 ¹⁾	IP22	2146	2000	636	2250	2xD8T+3xR8i

12-pulse diode

990	710	81	8	2000	ACS880-07-0990A-5+A004	NSIN-1380-6 ¹⁾	IP22	2145	1000	636	750	2xD7T+2xR8i
1320	900	82	12	4000	ACS880-07-1320A-5+A004	2xNSIN-0900-6 ¹⁾	IP22	2145	2000	636	750	2xD8T+2xR8i
1450	1000	82	12	4000	ACS880-07-1450A-5+A004	2xNSIN-0900-6 ¹⁾	IP22	2145	2000	636	750	2xD8T+2xR8i
1580	1100	82	16	4000	ACS880-07-1580A-5+A004	2xNSIN-1380-6 ¹⁾	IP22	2145	2000	636	1500	2xD8T+2xR8i
1800	1250	82	16	4000	ACS880-07-1800A-5+A004	2xNSIN-1380-6 ¹⁾	IP22	2145	2000	636	1500	2xD8T+3xR8i
1980	1400	82	16	4000	ACS880-07-1980A-5+A004	2xNSIN-1380-6 ¹⁾	IP22	2145	2000	636	1500	2xD8T+3xR8i

$U_N = 690$ V (range 525 to 690 V). The power ratings are valid at nominal voltage 690 V.

6-pulse diode

330	315	80	2	700	ACS880-07-0330A-7	NSIN485-6	IP22	2130	430	646	300	R10
370	355	80	2.3	700	ACS880-07-0370A-7	NSIN485-6	IP22	2130	430	646	300	R10
425	450	80	2.4	2000	ACS880-07-0425A-7	NSIN900-6	IP22	2130	1030	646	700	R10
470	500	80	3.2	2000	ACS880-07-0470A-7	NSIN900-6	IP22	2130	1030	646	700	R11
522	560	80	3.6	2000	ACS880-07-0522A-7	NSIN900-6	IP22	2130	1030	646	700	R11
590	630	80	4	2000	ACS880-07-0590A-7	NSIN900-6	IP22	2130	1030	646	700	R11
650	710	80	4.9	2000	ACS880-07-0650A-7	NSIN900-6	IP22	2130	1030	646	700	R11
721	710	80	4.9	2000	ACS880-07-0721A-7	NSIN900-6	IP22	2130	1030	646	700	R11
800	800	80	7	2000	ACS880-07-0800A-7	NSIN-0900-6 ¹⁾	IP22	2145	1000	636	550	D8T+2xR8i
900	900	81	9	2000	ACS880-07-0900A-7	NSIN-1380-6 ¹⁾	IP22	2145	1000	636	750	D8T+2xR8i
1160	1100	81	9	2000	ACS880-07-1160A-7	NSIN-1380-6 ¹⁾	IP22	2145	1000	636	750	2xD8T+2xR8i
1450	1400	82	14	4000	ACS880-07-1450A-7	2xNSIN-0900-6 ¹⁾	IP22	2145	2000	636	1100	2xD8T+3xR8i
1650	1600	82	18	4000	ACS880-07-1650A-7	2xNSIN-1380-6 ¹⁾	IP22	2145	2000	636	1500	2xD8T+3xR8i
1950	1900	82	18	4000	ACS880-07-1950A-7	2xNSIN-1380-6 ¹⁾	IP22	2145	2000	636	1500	3xD8T+4xR8i
2300	2200	82	18	4000	ACS880-07-2300A-7	2xNSIN-1380-6 ¹⁾	IP22	2145	2000	636	1500	3xD8T+4xR8i
2600	2500	82	18	4000	ACS880-07-2600A-7	3xNSIN-1380-6 ¹⁾	IP22	2145	3000	636	1500	4xD8T+5xR8i
2860	2800	82	18	4000	ACS880-07-2860A-7	3xNSIN-1380-6 ¹⁾	IP22	2145	3000	636	1500	4xD8T+5xR8i

12-pulse diode

800	768	80	7	2000	ACS880-07-0800A-7+A004	NSIN-0900-6 ¹⁾	IP22	2145	1000	636	550	2xD7T+2xR8i
950	912	81	9	2000	ACS880-07-0950A-7+A004	NSIN-1380-6 ¹⁾	IP22	2145	1000	636	750	2xD8T+2xR8i
1160	1114	81	9	2000	ACS880-07-1160A-7+A004	NSIN-1380-6 ¹⁾	IP22	2145	1000	636	750	2xD8T+2xR8i
1450	1392	82	14	4000	ACS880-07-1450A-7+A004	2xNSIN-0900-6 ¹⁾	IP22	2145	2000	636	1100	2xD8T+3xR8i
1650	1584	82	18	4000	ACS880-07-1650A-7+A004	2xNSIN-1380-6 ¹⁾	IP22	2145	2000	636	1500	2xD8T+3xR8i
1950	1872	82	18	4000	ACS880-07-1950A-7+A004	2xNSIN-1380-6 ¹⁾	IP22	2145	2000	636	1500	4xD8T+4xR8i
2300	2208	82	18	4000	ACS880-07-2300A-7+A004	2xNSIN-1380-6 ¹⁾	IP22	2145	2000	636	1500	4xD8T+4xR8i
2600	2496	83	27	6000	ACS880-07-2600A-7+A004	3xNSIN-1380-6 ¹⁾	IP22	2145	3000	636	1500	4xD8T+5xR8i
2860	2746	83	27	6000	ACS880-07-2860A-7+A004	3xNSIN-1380-6 ¹⁾	IP22	2145	3000	636	1500	4xD8T+5xR8i

¹⁾ Available as application engineered (+P902)

Sine filters, ACS880-17/-37

I_N A	P_N kW	Noise level dB	Heat dissipation kW	Air flow m ³ /h	Type designation	Filter size	Degree of protection	Filter				Frame size
								Height mm	Width mm	Depth mm	Weight kg	

$U_N = 400$ V (range 380 to 415 V). The power ratings are valid at nominal voltage 400 V.

450	250	80	2	700	ACS880-17-0450A-3	NSIN-0485-6	IP22	2145	400	636	350	R8i
620	355	80	5	2000	ACS880-17-0620A-3	NSIN-0900-6	IP22	2145	1000	636	550	R8i
870	500	81	7	2000	ACS880-17-0870A-3	NSIN-1380-6	IP22	2145	1000	636	750	R8i
1110	630	81	7	2000	ACS880-17-1110A-3	NSIN-1380-6	IP22	2145	1000	636	750	2×R8i
1210	710	81	7	2000	ACS880-17-1210A-3	NSIN-1380-6	IP22	2145	1000	636	750	2×R8i
1430	800	82	10	4000	ACS880-17-1430A-3	2xNSIN-0900-6 ¹⁾	IP22	2145	2000	636	1100	2×R8i
1700	1000	82	14	4000	ACS880-17-1700A-3	2xNSIN-1380-6 ¹⁾	IP22	2145	2000	636	1500	2×R8i
2060	1200	82	14	4000	ACS880-17-2060A-3	2xNSIN-1380-6 ¹⁾	IP22	2145	2000	636	1500	3×R8i
2530	1400	83	21	6000	ACS880-17-2530A-3	3xNSIN-1380-6 ¹⁾	IP22	2145	3000	636	2250	3×R8i

$U_N = 500$ V (range 380 to 500 V). The power ratings are valid at nominal voltage 500 V.

420	250	80	2,5	700	ACS880-17-0420A-5	NSIN-0485-6	IP22	2145	400	636	350	R8i
570	400	80	6	2000	ACS880-17-0570A-5	NSIN-0900-6	IP22	2145	1000	636	550	R8i
780	560	80	6	2000	ACS880-17-0780A-5	NSIN-0900-6	IP22	2145	1000	636	550	R8i
1010	710	81	8	2000	ACS880-17-1010A-5	NSIN-1380-6	IP22	2145	1000	636	750	2×R8i
1110	800	81	8	2000	ACS880-17-1110A-5	NSIN-1380-6	IP22	2145	1000	636	750	2×R8i
1530	1100	82	16	4000	ACS880-17-1530A-5	2xNSIN-1380-6 ¹⁾	IP22	2145	2000	636	1500	2×R8i
1980	1400	82	16	4000	ACS880-17-1980A-5	2xNSIN-1380-6 ¹⁾	IP22	2145	2000	636	1500	3×R8i
2270	1600	82	16	4000	ACS880-17-2270A-5	2xNSIN-1380-6 ¹⁾	IP22	2145	2000	636	1500	3×R8i

$U_N = 690$ V (range 525 to 690 V). The power ratings are valid at nominal voltage 690 V.

320	315	80	3	700	ACS880-17-0320A-7	NSIN-0485-6	IP22	2145	400	636	350	R8i
390	355	80	3	700	ACS880-17-0390A-7	NSIN-0485-6	IP22	2145	400	636	350	R8i
580	560	80	7	2000	ACS880-17-0580A-7	NSIN-0900-6	IP22	2145	1000	636	550	R8i
660	630	80	7	2000	ACS880-17-0660A-7	NSIN-0900-6	IP22	2145	1000	636	550	2×R8i
770	710	80	7	2000	ACS880-17-0770A-7	NSIN-0900-6	IP22	2145	1000	636	550	2×R8i
950	900	81	9	2000	ACS880-17-0950A-7	NSIN-1380-6	IP22	2145	1000	636	750	2×R8i
1130	1100	81	9	2000	ACS880-17-1130A-7	NSIN-1380-6	IP22	2145	1000	636	750	2×R8i
1450	1400	82	14	4000	ACS880-17-1450A-7	2xNSIN-0900-6 ¹⁾	IP22	2145	2000	636	1100	3×R8i
1680	1600	82	18	4000	ACS880-17-1680A-7	2xNSIN-1380-6 ¹⁾	IP22	2145	2000	636	1500	3×R8i
1950	1900	82	18	4000	ACS880-17-1950A-7	2xNSIN-1380-6 ¹⁾	IP22	2145	2000	636	1500	4×R8i
2230	2200	82	18	4000	ACS880-17-2230A-7	2xNSIN-1380-6 ¹⁾	IP22	2145	2000	636	1500	4×R8i
2770	2700	83	27	6000	ACS880-17-2770A-7	3xNSIN-1380-6 ¹⁾	IP22	2145	3000	636	2250	5×R8i
3310	3200	83	27	6000	ACS880-17-3310A-7	3xNSIN-1380-6 ¹⁾	IP22	2145	3000	636	2250	6×R8i

Brake options

Brake chopper

The brake chopper is built-in as standard for the ACS880-01 frame sizes R1 to R4. For other frames, a brake chopper is a selectable internal option. Braking control is integrated into the ACS880 single drives. It not only controls braking, but also supervises system status and detects failures such as brake resistor and resistor cable short-circuits, chopper short-circuit, and calculated resistor overtemperature.

Brake resistor

The brake resistors are separately available for ACS880-01 and built in for the cabinet-built ACS880-07. Resistors other than the standard option resistors may be used, provided that the specified resistance value is not decreased and that the heat

dissipation capacity of the resistor is sufficient for the drive application. No separate fuses in the brake circuit are required if the conditions for eg. the mains cable is protected with fuses and no mains cable/fuse overrating takes place.



Brake resistor, SACE15RE13

Brake options, ACS880-01

$U_N = 230\text{ V}$ (range 208 to 240 V)							
Braking power		Brake resistor(s)				Type designation	Frame size
P_{brcont} [kW]	R_{min} ohm	Type	R [Ohm]	E_r [kJ]	P_{rcont} [kW]		
0.75	65	JBR-03	80	40	0.14	ACS880-01-04A6-2	R1
1.1	65	JBR-03	80	40	0.14	ACS880-01-06A6-2	R1
1.5	65	JBR-03	80	40	0.14	ACS880-01-07A5-2	R1
2.2	65	JBR-03	80	40	0.14	ACS880-01-10A6-2	R1
4	18	SACE15RE22	22	420	2	ACS880-01-16A8-2	R2
5.5	18	SACE15RE22	22	420	2	ACS880-01-24A3-2	R2
7.5	13	SACE15RE13	13	435	2	ACS880-01-031A-2	R3
11	12	SACE15RE13	13	435	2	ACS880-01-046A-2	R4
11	12	SACE15RE13	13	435	2	ACS880-01-061A-2	R4
18.5	6	SAFUR90F575	8	1800	4.5	ACS880-01-075A-2+D150	R5
22	6	SAFUR90F575	8	1800	4.5	ACS880-01-087A-2+D150	R5
30	3.5	SAFUR125F500	4	3600	9	ACS880-01-115A-2+D150	R6
37	3.5	SAFUR125F500	4	3600	9	ACS880-01-145A-2+D150	R6
45	2.4	SAFUR200F500	2.7	5400	13.5	ACS880-01-170A-2+D150	R7
55	2.4	SAFUR200F500	2.7	5400	13.5	ACS880-01-206A-2+D150	R7
75	1.8	SAFUR200F500	2.7	5400	13.5	ACS880-01-274A-2+D150	R8

$U_N = 400\text{ V}$ (range 380 to 415 V)							
Braking power		Brake resistor(s)				Type designation	Frame size
P_{brcont} [kW]	R_{min} ohm	Type	R [Ohm]	E_r [kJ]	P_{rcont} [kW]		
0.75	78	JBR-03	80	40	0.14	ACS880-01-02A4-3	R1
1.1	78	JBR-03	80	40	0.14	ACS880-01-03A3-3	R1
1.5	78	JBR-03	80	40	0.14	ACS880-01-04A0-3	R1
2.2	78	JBR-03	80	40	0.14	ACS880-01-05A6-3	R1
3	78	JBR-03	80	40	0.14	ACS880-01-07A2-3	R1
4	78	JBR-03	80	40	0.14	ACS880-01-09A4-3	R1
5.5	78	JBR-03	80	40	0.14	ACS880-01-12A6-3	R1
7.5	39	SACE08RE44	44	210	1	ACS880-01-017A-3	R2
11	39	SACE08RE44	44	210	1	ACS880-01-025A-3	R2
15	19	SACE15RE22	22	420	2	ACS880-01-032A-3	R3
18.5	19	SACE15RE22	22	420	2	ACS880-01-038A-3	R3
22	13	SACE15RE13	13	435	2	ACS880-01-045A-3	R4
22	13	SACE15RE13	13	435	2	ACS880-01-061A-3	R4
37	8	SAFUR90F575	8	1800	4.5	ACS880-01-072A-3+D150	R5
45	8	SAFUR90F575	8	1800	4.5	ACS880-01-087A-3+D150	R5
55	5.4	SAFUR80F500	6	2400	6	ACS880-01-105A-3+D150	R6
75	5.4	SAFUR80F500	6	2400	6	ACS880-01-145A-3+D150	R6
90	3.3	SAFUR125F500	4	3600	9	ACS880-01-169A-3+D150	R7
110	3.3	SAFUR125F500	4	3600	9	ACS880-01-206A-3+D150	R7
132	2.3	SAFUR200F500	2.7	5400	13.5	ACS880-01-246A-3+D150	R8
132	2.3	SAFUR200F500	2.7	5400	13.5	ACS880-01-293A-3+D150	R8
160	2	SAFUR200F500	2.7	5400	13.5	ACS880-01-363A-3+D150	R9
160	2	SAFUR200F500	2.7	5400	13.5	ACS880-01-430A-3+D150	R9

All brake resistors are to be installed outside the converter module.
 The SACE brake resistors are built-in to an IP21 metal housing.
 The SAFUR brake resistors are built-in to an IP00 metal frame.

Brake options, ACS880-01

$U_N = 500 \text{ V}$ (range 380 to 500 V)							
Braking power		Brake resistor(s)				Type designation	Frame size
P_{brcont} [kW]	R_{min} ohm	Type	R [Ohm]	E_r [kJ]	P_{rcont} [kW]		
0.75	78	JBR-03	80	40	0.14	ACS880-01-02A1-5	R1
1.1	78	JBR-03	80	40	0.14	ACS880-01-03A0-5	R1
1.5	78	JBR-03	80	40	0.14	ACS880-01-03A4-5	R1
2.2	78	JBR-03	80	40	0.14	ACS880-01-04A8-5	R1
3	78	JBR-03	80	40	0.14	ACS880-01-05A2-5	R1
4	78	JBR-03	80	40	0.14	ACS880-01-07A6-5	R1
5.5	78	JBR-03	80	40	0.14	ACS880-01-11A0-5	R1
7.5	39	SACE08RE44	44	210	1	ACS880-01-014A-5	R2
11	39	SACE08RE44	44	210	1	ACS880-01-021A-5	R2
15	19	SACE15RE22	22	420	2	ACS880-01-027A-5	R3
18.5	19	SACE15RE22	22	420	2	ACS880-01-034A-5	R3
22	13	SACE15RE13	13	435	2	ACS880-01-040A-5	R4
22	13	SACE15RE13	13	435	2	ACS880-01-052A-5	R4
37	8	SAFUR90F575	8	1800	4.5	ACS880-01-065A-5+D150	R5
45	8	SAFUR90F575	8	1800	4.5	ACS880-01-077A-5+D150	R5
55	5.4	SAFUR80F500	6	2400	6	ACS880-01-096A-5+D150	R6
75	5.4	SAFUR80F500	6	2400	6	ACS880-01-124A-5+D150	R6
90	3.3	SAFUR125F500	4	3600	9	ACS880-01-156A-5+D150	R7
110	3.3	SAFUR125F500	4	3600	9	ACS880-01-180A-5+D150	R7
132	2.3	SAFUR200F500	2.7	5400	13.5	ACS880-01-240A-5+D150	R8
132	2.3	SAFUR200F500	2.7	5400	13.5	ACS880-01-260A-5+D150	R8
160	2.3	SAFUR200F500	2.7	5400	13.5	ACS880-01-361A-5+D150	R9
160	2.3	SAFUR200F500	2.7	5400	13.5	ACS880-01-414A-5+D150	R9

$U_N = 690 \text{ V}$ (range 525 to 690 V)							
Braking power		Brake resistor(s)				Type designation	Frame size
P_{brcont} [kW]	R_{min} ohm	Type	R [Ohm]	E_r [kJ]	P_{rcont} [kW]		
6	18	SACE08RE44	44	210	1	ACS880-01-07A3-7+D150	R5
8	18	SACE08RE44	44	210	1	ACS880-01-09A8-7+D150	R5
11	18	SACE08RE44	44	210	1	ACS880-01-14A2-7+D150	R5
17	18	SACE15RE22	22	420	2	ACS880-01-018A-7+D150	R5
23	18	SACE15RE22	22	420	2	ACS880-01-022A-7+D150	R5
28	18	SACE15RE22	22	420	2	ACS880-01-026A-7+D150	R5
33	18	SACE15RE22	22	420	2	ACS880-01-035A-7+D150	R5
45	18	SACE15RE22	22	420	2	ACS880-01-042A-7+D150	R5
45	18	SACE15RE22	22	420	2	ACS880-01-049A-7+D150	R5
55	13	SACE15RE13	13	435	2	ACS880-01-061A-7+D150	R6
65	13	SACE15RE13	13	435	2	ACS880-01-084A-7+D150	R6
90	8	SAFUR90F575	8	1800	4.5	ACS880-01-098A-7+D150	R7
110	8	SAFUR90F575	8	1800	4.5	ACS880-01-119A-7+D150	R7
132	6	SAFUR80F500	6	2400	6	ACS880-01-142A-7+D150	R8
160	6	SAFUR80F500	6	2400	6	ACS880-01-174A-7+D150	R8
200	4	SAFUR125F500	4	3600	9	ACS880-01-210A-7+D150	R9
200	4	SAFUR125F500	4	3600	9	ACS880-01-271A-7+D150	R9

All brake resistors are to be installed outside the converter module.
 The JBR brake resistors are built-in to an IP20 metal housing.
 The SACE brake resistors are built-in to an IP21 metal housing.
 The SAFUR brake resistors are built-in to an IP00 metal frame.

Maximum braking power of the ACS880 equipped with the standard chopper and the standard resistor	
P_{brcont}	Continuous brake chopper power. The value applies to the minimum resistance value. With a higher resistance value the P_{brcont} may increase in some ACS880 units.
R	Resistance value for the listed resistor type.
R_{min}	Minimum allowable resistance value for the brake resistor.
E_r	Energy pulse that the resistor assembly will withstand (400 s duty cycle). This energy will heat the resistor element from 40 °C to the maximum allowable temperature.
P_{rcont}	Continuous power (heat) dissipation of the resistor when placed correctly. Energy E_r dissipates in 400 seconds.

Brake resistor	Height (mm)	Width (mm)	Depth (mm)	Weight (kg)
JBR-03	124	340	77	0.8
SACE08RE44	365	290	131	6.1
SACE15RE22	365	290	131	6.1
SACE15RE13	365	290	131	6.8
SAFUR80F500	600	300	345	14
SAFUR90F575	600	300	345	12
SAFUR125F500	1320	300	345	25
SAFUR200F500	1320	300	345	30

Brake options, ACS880-07

U _N = 400 V (range 380 to 415 V)							
Braking power		Brake resistor(s)				Type designation	Frame size
P _{brcont} [kW]	R _{min} Ohm	Type	R [Ohm]	E _r [kJ]	P _{rcont} [kW]		
55	5.4	SAFUR80F500	6	2400	6	ACS880-07-0105A-3+D150 ²⁾	R6
75	5.4	SAFUR80F500	6	2400	6	ACS880-07-0145A-3+D150 ²⁾	R6
90	3.3	SAFUR125F500	4	3600	9	ACS880-07-0169A-3+D150 ²⁾	R7
110	3.3	SAFUR125F500	4	3600	9	ACS880-07-0206A-3+D150 ²⁾	R7
132	2.3	SAFUR200F500	2.7	5400	13.5	ACS880-07-0246A-3+D150 ²⁾	R8
132	2.3	SAFUR200F500	2.7	5400	13.5	ACS880-07-0293A-3+D150 ²⁾	R8
160	2	SAFUR200F500 ¹⁾	2	7200	18	ACS880-07-0363A-3+D150 ²⁾	R9
160	2	SAFUR200F500 ¹⁾	2	7200	18	ACS880-07-0430A-3+D150 ²⁾	R9
250	2	2xSAFUR125F500	2	7200	18	ACS880-07-0505A-3+D150 ²⁾	R10
315	1.3	2xSAFUR200F500	1.35	10800	27	ACS880-07-0585A-3+D150 ²⁾	R10
315	1.3	2xSAFUR200F500	1.35	10800	27	ACS880-07-0650A-3+D150 ²⁾	R10
400	0.7	3xSAFUR200F500	0.90	16200	40	ACS880-07-0725A-3+D150 ²⁾	R11
400	0.7	3xSAFUR200F500	0.90	16200	40	ACS880-07-0810A-3+D150 ²⁾	R11
400	0.7	3xSAFUR200F500	0.90	16200	40	ACS880-07-0880A-3+D150 ²⁾	R11

U _N = 400 V (range 380 to 415 V)													
Nominal ratings					Duty cycle (1min/5min)		Duty cycle (10s/60s)		Brake Chopper Type	Brake resistor Type	Er [kJ]	Type designation	Frame size
P _{brcont} [kW]	R Ohm	I _{max} A	I _{rms} A	P _{cont.} kW	P _{br.} kW	I _{rms} A	P _{br.} kW	I _{rms} A					
6-pulse diode													
706	0,60	1090	168	108	333	514	575	888	2xNBRA659	2 x (2 x SAFUR180F460)	24000	ACS880-07-1140A-3	D8T+2xR8i
1058	0,40	1635	252	162	500	771	862	1332	3xNBRA659	3 x (2 x SAFUR180F460)	36000	ACS880-07-1250A-3	2xD8T+2xR8i
1058	0,40	1635	252	162	500	771	862	1332	3xNBRA659	3 x (2 x SAFUR180F460)	36000	ACS880-07-1480A-3	2xD8T+2xR8i
1058	0,40	1635	252	162	500	771	862	1332	3xNBRA659	3 x (2 x SAFUR180F460)	36000	ACS880-07-1760A-3	2xD8T+2xR8i
12-pulse diode													
706	0,60	1090	168	108	333	514	575	888	2xNBRA659	2 x (2 x SAFUR180F460)	24000	ACS880-07-0990A-3+A004	2xD7T+2xR8i
1058	0,40	1635	252	162	500	771	862	1332	2xNBRA659	2 x (2 x SAFUR180F460)	24000	ACS880-07-1140A-3+A004	2xD8T+2xR8i
1058	0,40	1635	252	162	500	771	862	1332	3xNBRA659	3 x (2 x SAFUR180F460)	36000	ACS880-07-1250A-3+A004	2xD8T+2xR8i
1058	0,40	1635	252	162	500	771	862	1332	3xNBRA659	3 x (2 x SAFUR180F460)	36000	ACS880-07-1480A-3+A004	2xD8T+2xR8i
1058	0,40	1635	252	162	500	771	862	1332	3xNBRA659	3 x (2 x SAFUR180F460)	36000	ACS880-07-1760A-3+A004	2xD8T+2xR8i

U _N = 500 V (range 380 to 500 V)							
Braking power		Brake resistor(s)				Type designation	Frame size
P _{brcont} [kW]	R _{min} Ohm	Type	R [Ohm]	E _r [kJ]	P _{rcont} [kW]		
55	5.4	SAFUR80F500	6	2400	6	ACS880-07-0096A-5+D150 ²⁾	R6
75	5.4	SAFUR80F500	6	2400	6	ACS880-07-0124A-5+D150 ²⁾	R6
90	3.3	SAFUR125F500	4	3600	9	ACS880-07-0156A-5+D150 ²⁾	R7
110	3.3	SAFUR125F500	4	3600	9	ACS880-07-0180A-5+D150 ²⁾	R7
132	2.3	SAFUR200F500	2.7	5400	13.5	ACS880-07-0240A-5+D150 ²⁾	R8
132	2.3	SAFUR200F500	2.7	5400	13.5	ACS880-07-0260A-5+D150 ²⁾	R8
160	2.3	SAFUR200F500	2.7	5400	13.5	ACS880-07-0361A-5+D150 ²⁾	R9
160	2.3	SAFUR200F500	2.7	5400	13.5	ACS880-07-0414A-5+D150 ²⁾	R9
250	2	2xSAFUR125F500	2	7200	18	ACS880-07-0460A-5+D150 ²⁾	R10
250	2	2xSAFUR125F500	2	7200	18	ACS880-07-0503A-5+D150 ²⁾	R10
315	1.3	2xSAFUR200F500	1.35	10800	27	ACS880-07-0583A-5+D150 ²⁾	R10
315	1.3	2xSAFUR200F500	1.35	10800	27	ACS880-07-0635A-5+D150 ²⁾	R10
400	0.7	3xSAFUR200F500	0.90	16200	40	ACS880-07-0715A-5+D150 ²⁾	R11
400	0.7	3xSAFUR200F500	0.90	16200	40	ACS880-07-0820A-5+D150 ²⁾	R11
400	0.7	3xSAFUR200F500	0.90	16200	40	ACS880-07-0880A-5+D150 ²⁾	R11

U _N = 500 V (range 380 to 500 V)													
Nominal ratings					Duty cycle (1min/5min)		Duty cycle (10s/60s)		Brake Chopper Type	Brake resistor Type	Er [kJ]	Type designation	Frame size
P _{brcont} kW	R ohm	I _{max} A	I _{rms} A	P _{cont.} kW	P _{br.} kW	I _{rms} A	P _{br.} kW	I _{rms} A					
6-pulse diode													
806	0,68	1210	134	108	333	412	575	710	2xNBRA-659	2 x (2 x SAFUR200F500)	21600	ACS880-07-1070A-5	D8T+2xR8i
1208	0,45	1815	201	162	500	618	862	1065	3xNBRA-659	3 x (2 x SAFUR200F500)	32400	ACS880-07-1320A-5	2xD8T+2xR8i
1208	0,45	1815	201	162	500	618	862	1065	3xNBRA-659	3 x (2 x SAFUR180F460)	32400	ACS880-07-1450A-5	2xD8T+2xR8i
1208	0,45	1815	201	162	500	618	862	1065	3xNBRA-659	3 x (2 x SAFUR200F500)	32400	ACS880-07-1580A-5	2xD8T+2xR8i
12-pulse diode													
806	0,68	1210	134	108	333	412	575	710	2xNBRA-659	2 x (2 x SAFUR200F500)	21600	ACS880-07-0990A-5+A004	2xD7T+2xR8i
1208	0,45	1815	201	162	500	618	862	1065	3xNBRA-659	3 x (2 x SAFUR200F500)	32400	ACS880-07-1320A-5+A004	2xD8T+2xR8i
1208	0,45	1815	201	162	500	618	862	1065	3xNBRA-659	3 x (2 x SAFUR180F460)	32400	ACS880-07-1450A-5+A004	2xD8T+2xR8i
1208	0,45	1815	201	162	500	618	862	1065	3xNBRA-659	3 x (2 x SAFUR200F500)	32400	ACS880-07-1580A-5+A004	2xD8T+2xR8i

Brake options, ACS880-07

$U_N = 690 \text{ V}$ (range 525 to 690 V)

Braking power		Brake resistor(s)				Type designation	Frame size
P_{brcont} [kW]	R_{min} Ohm	Type	R [Ohm]	E_r [kJ]	P_{rcont} [kW]		
55	13	SACE15RE13	13	435	2	ACS880-07-0061A-7+D150 ²⁾	R6
65	13	SACE15RE13	13	435	2	ACS880-07-0084A-7+D150 ²⁾	R6
90	8	SAFUR90F575	8	1800	4.5	ACS880-07-0098A-7+D150 ²⁾	R7
110	8	SAFUR90F575	8	1800	4.5	ACS880-07-0119A-7+D150 ²⁾	R7
132	6	SAFUR80F500	6	2400	6	ACS880-07-0142A-7+D150 ²⁾	R8
160	6	SAFUR80F500	6	2400	6	ACS880-07-0174A-7+D150 ²⁾	R8
200	4	SAFUR125F500	4	3600	9	ACS880-07-0210A-7+D150 ²⁾	R9
200	4	SAFUR125F500	4	3600	9	ACS880-07-0271A-7+D150 ²⁾	R9
285	2.2	SAFUR200F500	2.7	3600	13	ACS880-07-0330A-7+D150 ²⁾	R10
285	2.2	SAFUR200F500	2.7	3600	13	ACS880-07-0370A-7+D150 ²⁾	R10
285	2.2	SAFUR200F500	2.7	3600	13	ACS880-07-0430A-7+D150 ²⁾	R10
350	2.0	2xSAFUR125F500	2.0	7200	18	ACS880-07-0425A-7+D150 ²⁾	R11
350	2.0	2xSAFUR125F500	2.0	7200	18	ACS880-07-0470A-7+D150 ²⁾	R11
350	2.0	2xSAFUR125F500	2.0	7200	18	ACS880-07-0522A-7+D150 ²⁾	R11
400	1.8	2xSAFUR125F500	2.0	7200	18	ACS880-07-0590A-7+D150 ²⁾	R11
400	1.8	2xSAFUR125F500	2.0	7200	18	ACS880-07-0650A-7+D150 ²⁾	R11
400	1.8	2xSAFUR125F500	2.0	7200	18	ACS880-07-0721A-7+D150 ²⁾	R11

Note:

¹⁾ = Connected in parallel

²⁾ = +D151 if resistor is ordered

All brake resistors are to be installed inside the drive cabinet.

Brake options for high power types, contact your local ABB.

$U_N = 690 \text{ V}$ (range 525 to 690 V)

Nominal ratings					Duty cycle (1min/5min)		Duty cycle (10s/60s)		Brake Chopper Type	Brake resistor Type	Er [kJ]	Type designation	Frame size
P_{brcont} kW	R ohm	I_{max} A	I_{rms} A	$P_{cont.}$ kW	$P_{br.}$ kW	I_{rms} A	$P_{br.}$ kW	I_{rms} A					
6-pulse diode													
1211	0,45	2505	291	162	500	447	862	771	3xNBRA-669	3 x (2 x SAFUR200F500)	32400	ACS880-07-0800A-7	D8T+2xR8i
1211	0,45	2505	291	162	500	447	862	771	3xNBRA-669	3 x (2 x SAFUR200F500)	32400	ACS880-07-0900A-7	D8T+2xR8i
1211	0,45	2505	291	162	500	447	862	771	3xNBRA-669	3 x (2 x SAFUR200F500)	32400	ACS880-07-1160A-7	2xD8T+2xR8i
12-pulse diode													
1211	0,45	2505	291	162	500	447	862	771	3xNBRA-669	3 x (2 x SAFUR200F500)	32400	ACS880-07-0800A-7+A004	2xD7T+2xR8i
1211	0,45	2505	291	162	500	447	862	771	3xNBRA-669	3 x (2 x SAFUR200F500)	32400	ACS880-07-0950A-7+A004	2xD8T+2xR8i
1211	0,45	2505	291	162	500	447	862	771	3xNBRA-669	3 x (2 x SAFUR200F500)	32400	ACS880-07-1160A-7+A004	2xD8T+2xR8i

For other frame sizes application engineering only

Maximum braking power of the ACS880 equipped with the standard chopper and the standard resistor

P_{brcont}	Continuous brake chopper power. The value applies to the minimum resistance value. With a higher resistance value the P_{brcont} may increase in some ACS880 units.
R	Resistance value for the listed resistor type.
R_{min}	Minimum allowable resistance value for the brake resistor.
E_r	Energy pulse that the resistor assembly will withstand (400 s duty cycle). This energy will heat the resistor element from 40 °C to the maximum allowable temperature.
P_{rcont}	Continuous power (heat) dissipation of the resistor when placed correctly. Energy E_r dissipates in 400 seconds.

Brake resistor	Height (mm)	Width (mm)	Depth (mm)	Weight (kg)
JBR-03	124	340	77	0.8
SACE08RE44	365	290	131	6.1
SACE15RE22	365	290	131	6.1
SACE15RE13	365	290	131	6.8
SAFUR80F500	600	300	345	14
SAFUR90F575	600	300	345	12
SAFUR125F500	1320	300	345	25
SAFUR200F500	1320	300	345	30

Additional width for ACS880-07

Resistor quantity	Width (mm)
1xSAFUR	400
2xSAFUR	800

Brake options, ACS880-37

$U_N = 400\text{ V}$ (range 380 to 415 V)													
Nominal ratings					Duty cycle (1min/5min)		Duty cycle (10s/60s)		Brake Chopper Type	Brake resistor Type	Er [kJ]	Type designation	Frame size
$P_{br,max}$ kW	R ohm	I_{max} A	I_{rms} A	$P_{cont.}$ kW	$P_{br.}$ kW	I_{rms} A	$P_{br.}$ kW	I_{rms} A					
353	1.2	545	84	54	167	444	287	444	NBRA659	2 x SAFUR180F460	12000	ACS880-37-0450A-3	R8i
353	1.2	545	84	54	167	444	287	444	NBRA659	2 x SAFUR180F460	12000	ACS880-37-0450A-3	R8i
706	0.6	1090	168	108	333	514	575	888	2xNBRA659	2 x (2 x SAFUR180F460)	24000	ACS880-37-0870A-3	R8i
706	0.6	1090	168	108	333	514	575	888	2xNBRA659	2 x (2 x SAFUR180F460)	24000	ACS880-37-1110A-3	2xR8i
706	0.6	1090	168	108	333	514	575	888	2xNBRA659	2 x (2 x SAFUR180F460)	24000	ACS880-37-1210A-3	2xR8i
1058	0.4	1635	252	162	500	771	862	1332	3xNBRA659	3 x (2 x SAFUR180F460)	36000	ACS880-37-1430A-3	2xR8i
1058	0.4	1635	252	162	500	771	862	1332	3xNBRA659	3 x (2 x SAFUR180F460)	36000	ACS880-37-1700A-3	2xR8i

$U_N = 500\text{ V}$ (range 380 to 500 V)													
Nominal ratings					Duty cycle (1min/5min)		Duty cycle (10s/60s)		Brake Chopper Type	Brake resistor Type	Er [kJ]	Type designation	Frame size
$P_{br,cont}$ kW	R ohm	I_{max} A	I_{rms} A	$P_{cont.}$ kW	$P_{br.}$ kW	I_{rms} A	$P_{br.}$ kW	I_{rms} A					
403	1.35	605	67	54	167	206	287	355	NBRA659	2 x SAFUR200F500	10800	ACS880-37-0420A-5	R8i
403	1.35	605	67	54	167	206	287	355	NBRA659	2 x SAFUR200F500	10800	ACS880-37-0570A-5	R8i
806	0.68	1210	134	108	333	412	575	710	2xNBRA659	2 x (2 x SAFUR200F500)	21600	ACS880-37-0780A-5	R8i
806	0.68	1210	134	108	333	412	575	710	2xNBRA659	2 x (2 x SAFUR180F460)	21600	ACS880-37-1010A-5	2xR8i
806	0.68	1210	134	108	333	412	575	710	2xNBRA659	2 x (2 x SAFUR200F500)	21600	ACS880-37-1110A-5	2xR8i
1208	0.45	1815	201	162	500	618	862	1065	3xNBRA659	3 x (2 x SAFUR200F500)	32400	ACS880-37-1530A-5	2xR8i

$U_N = 690\text{ V}$ (range 525 to 690 V)													
Nominal ratings					Duty cycle (1min/5min)		Duty cycle (10s/60s)		Brake Chopper Type	Brake resistor Type	Er [kJ]	Type designation	Frame size
$P_{br,cont}$ kW	R ohm	I_{max} A	I_{rms} A	$P_{cont.}$ kW	$P_{br.}$ kW	I_{rms} A	$P_{br.}$ kW	I_{rms} A					
404	1.35	835	97	54	167	149	287	257	NBRA669	2 x SAFUR200F500	10800	ACS880-37-0320A-7	R8i
404	1.35	835	97	54	167	149	287	257	NBRA669	2 x SAFUR200F500	10800	ACS880-37-0390A-7	R8i
807	0.68	1670	194	108	333	298	575	514	2xNBRA669	2 x (2 x SAFUR200F500)	21600	ACS880-37-0580A-7	R8i
807	0.68	1670	194	108	333	298	575	514	2xNBRA669	2 x (2 x SAFUR200F500)	21600	ACS880-37-0660A-7	2xR8i
1211	0.45	2505	291	162	500	447	862	771	3xNBRA-669	3 x (2 x SAFUR200F500)	32400	ACS880-37-0770A-7	2xR8i
1211	0.45	2505	291	162	500	447	862	771	3xNBRA-669	3 x (2 x SAFUR200F500)	32400	ACS880-37-0950A-7	2xR8i
1211	0.45	2505	291	162	500	447	862	771	3xNBRA-669	3 x (2 x SAFUR200F500)	32400	ACS880-37-1130A-7	2xR8i

For other frame sizes application engineering only

du/dt filters

du/dt filtering suppresses inverter output voltage spikes and rapid voltage changes that stress motor insulation. Additionally, du/dt filtering reduces capacitive leakage currents and high frequency emission of the motor cable as well as high frequency losses and bearing currents in the motor. The need for du/dt filtering depends on the motor insulation. For information on the construction of the motor insulation, consult the manufacturer.

If the motor does not fulfil the following requirements, the lifetime of the motor might decrease. Insulated N-end (non-driven end) bearings and/or common mode filters are also required for motor bearing currents with motors bigger than 100 kW. For more information, please see the ACS880 hardware manuals.

Please see below about how to select a filter according to the motor.

Filter selection table for ACS880

Motor type	Nominal AC supply voltage	Requirements for		
		Motor insulation system	ABB du/dt and common mode filters, insulated N-end motor bearings	
			$P_N < 100$ kW and frame size < IEC 315	100 kW $\leq P_N < 350$ kW or IEC 315 \leq frame size < IEC 400
			$P_N < 134$ hp and frame size < NEMA 500	134 hp $\leq P_N < 469$ hp or NEMA 500 \leq frame size \leq NEMA 580
ABB motors				
Random-wound M2___, M3___ and M4___	$U_N \leq 500$ V	Standard	–	+ N
	500 V < $U_N \leq 600$ V	Standard	+ du/dt	+ du/dt + N
		or Reinforced	–	+ N
	600 V < $U_N \leq 690$ V (cable length ≤ 150 m)	Reinforced	+ du/dt	+ du/dt + N
600 V < $U_N \leq 690$ V (cable length > 150 m)	Reinforced	–	+ N	
Form-wound HX___ and AM___	380 V < $U_N \leq 690$ V	Standard	n/a	+ N + CMF
Old ¹⁾ form-wound HX___ and modular	380 V < $U_N \leq 690$ V	Check with the motor manufacturer	+ du/dt with voltages over 500 V + N + CMF	
Random-wound HX___ and AM___ ²⁾	0 V < $U_N \leq 500$ V	Enmelled wire with fiber glass taping	+ N + CMF	
	500 V < $U_N \leq 690$ V		+ du/dt + N + CMF	
HDP	Consult the motor manufacturer.			

¹⁾ Manufactured before 1.1.1998.

²⁾ For motors manufactured before 1.1.1998, check for additional instructions with the motor manufacturer.

Non-ABB motors

Random-wound and form-wound	$U_N \leq 420$ V	Standard $\hat{U}_{LL} = 1300$ V	–	+ N or CMF
	420 V < $U_N \leq 500$ V	Standard $\hat{U}_{LL} = 1300$ V	+ du/dt	+ du/dt + N or + du/dt + CMF
		or Reinforced: $\hat{U}_{LL} = 1600$ V, 0.2 microsecond rise time	–	+ N or CMF
	500 V < $U_N \leq 600$ V	Reinforced: $\hat{U}_{LL} = 1600$ V	+ du/dt	+ du/dt + N or + du/dt + CMF
		or Reinforced: $\hat{U}_{LL} = 1800$ V	–	+ N or CMF
	600 V < $U_N \leq 690$ V	Reinforced: $\hat{U}_{LL} = 1800$ V	+ du/dt	+ du/dt + N
Reinforced: $\hat{U}_{LL} = 2000$ V, 0.3 microsecond rise time		–	+ N or CMF	

The abbreviations used in the table are defined below

Abbr.	Definition
U_N	Nominal AC line voltage.
\hat{U}_{LL}	Peak line-to-line voltage at motor terminals which the motor insulation must withstand.
P_N	Motor nominal power.
du/dt	du/dt filter at the output of the drive. Available from ABB as an optional add-on kit.
CMF	Common mode filter. Depending on the drive type, CMF is available from ABB as a factory-installed option (+208) or as an optional add-on kit.
N	N-end bearing: insulated motor non-drive end bearing.
n/a	Motors of this power range are not available as standard units. Consult the motor manufacturer.

du/dt filters

External du/dt filters for ACS880-01

ACS880			du/dt filter type (3 filters included in kits marked *)											
			Unprotected (IP00)				Protected to IP22			Protected to IP54				
			NOCH0016-60	NOCH0030-60	NOCH0070-60	NOCH0120-60*)	FOCH0260-70	FOCH0320-50	NOCH0016-62	NOCH0030-62	NOCH0070-62	NOCH0120-62	NOCH0016-65	NOCH0030-65
400 V	500 V	690 V												
02A4-3	02A1-5		x					x			x			
03A3-3	03A0-5		x					x			x			
	03A4-5		x					x			x			
04A0-3	04A8-5		x					x			x			
05A6-3	05A2-5		x					x			x			
07A2-3	07A6-5	07A3-7	x					x			x			
09A4-3		09A8-7	x					x			x			
12A6-3	11A0-5		x					x			x			
	14A2-7		x					x			x			
017A-3	014A-5		x					x			x			
	018A-7		x					x			x			
	021A-5	022A-7	x					x			x			
025A-3		026A-7	x					x			x			
032A-3	027A-5			x				x			x			
	034A-5	035A-7		x				x			x			
038A-3	040A-5	042A-7		x				x			x			
045A-3	052A-5	049A-7		x				x			x			
061A-3				x				x			x			
072A-3	065A-5	061A-7			x				x				x	
	077A-5				x				x				x	
087A-3		084A-7			x				x				x	
105A-3	096A-5	098A-7			x				x				x	
145A-3	124A-5	119A-7				x								
	156A-5	142A-7				x								
169A-3	180A-5	174A-7				x								
206A-3	240A-5	210A-7				x								
246A-3	260A-5	271A-7				x								
293A-3						x								
363A-3	361A-5						x							
430A-3	414A-5						x							

Applicability

Separate du/dt filters are available for ACS880-01. Unprotected IP00 filters must be placed into an enclosure that provides an adequate degree of protection.

Factory-installed du/dt filters are available for the ACS880-07. They are installed inside the drive cabinet.

Dimensions and weights of the du/dt filters

du/dt filter	Height (mm)	Width (mm)	Depth (mm)	Weight (kg)
NOCH0016-60	195	140	115	2.4
NOCH0016-62/65	323	199	154	6
NOCH0030-60	215	165	130	4.7
NOCH0030-62/65	348	249	172	9
NOCH0070-60	261	180	150	9.5
NOCH0070-62/65	433	279	202	15.5
NOCH0120-60 ³⁾	200	154	106	7
NOCH0120-62/65	765	308	256	45
NOCH0260-60 ³⁾	383	185	111	12
FOCH0260-70	382	340	254	47
FOCH0320-50	662	319	293	65
FOCH0610-70	662	319	293	65

³⁾ 3 filters included, dimensions apply for one filter.



NOCH0016-62

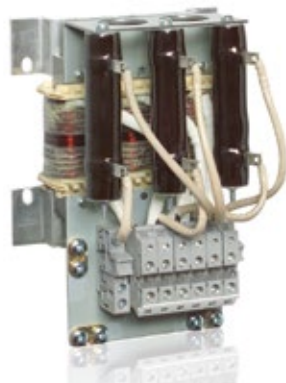

NOCH0016-60



NOCH0016-65



FOCH0610-70

Dimensioning tool for selecting the optimal drive

DriveSize is designed to help select the optimal drive, motor and transformer for the application. Based on data supplied by the user, the tool calculates and suggests which drive and motors to use. DriveSize uses technical specifications found in our technical catalogs and manuals. It provides default values which can be changed by the user.

DriveSize creates documents for drive and motor dimensioning based on the load, network and cooling data provided by the user. Dimensioning results can be viewed graphically and numerically in the tool.

The tool can be used to calculate currents and network harmonics for a single supply unit or a whole system. The user can import a user-defined motor database by using a separate template that comes with the installation package. DriveSize is easy to use and has shortcut keys to make navigation quicker.

Easy to access and use

DriveSize is a free software and can be used either online or downloaded for PC from www.abb.com/drives.





Summary of features and options

Power and voltage range	Ordering code	ACS880-01	ACS880-07	ACS880-07	ACS880-17	ACS880-37
		R1 to R9	R6 to R11	n×R8i	n×R8i ⁹⁾	n×R8i ⁹⁾
		kW	kW	kW	kW	kW
230 V		0.55 to 75				
400 V		0.55 to 250	45 to 500	400 to 1400	160 to 1200	160 to 1200
500 V		0.55 to 250	45 to 630	560 to 1400	200 to 1600	200 to 1600
690 V		4 to 250	45 to 710	560 to 2800	200 to 3200	200 to 3200
Mounting						
Wall-mounting		●	–	–	–	–
For cabinet mounting	+P940, +944	□	–	–	–	–
Cabinet-built		–	●	●	●	●
Flange mounting	+C135	□ ²⁰⁾	–	–	–	–
Cabling						
Bottom entry and exit		●	●	●	●	●
Top entry and exit		–	□	□	□	□
Degree of protection						
IP20 (UL type 1)	+P940, +944	□	–	–	–	–
IP21 (UL type 1)		●	–	–	–	–
IP22 (UL type 1)		–	●	●	●	●
IP42 (UL type 1)	+B054	–	□	□	□	□
IP54 (UL type 12)	+B055	–	□	□	□	□
IP55 (UL type 12)	+B056	□	–	–	–	–
Motor control						
DTC motor control		●	●	●	●	●
Software						
Primary control program, for more details see section: Standard software for scalable control and functionality		●	●	●	●	●
Drive application programming based on IEC 61131-3 using Automation Builder	+N8010	□	□	□	□ ¹¹⁾	□ ¹¹⁾
Application control program for winder	+N5000	□	□	□	□	□
Application control program for crane	+N5050	□	□	□	□	□
Application control program for centrifuge/decanter	+N5150	□	□	□	□	□ ¹¹⁾
Application control program for PCP/ESP pump	+N5200	□	□	□	□	□
Application control program for Rod pump	+N5250	□ ¹¹⁾	□ ¹¹⁾	□ ¹¹⁾	□ ¹¹⁾	□ ¹¹⁾
Application control program for cooling tower direct drive	+N5350					
Application control program for PCP/ESP pump with SynRM	+N5400					
Support for asynchronous motor		●	●	●	●	●
Support for permanent magnet motor		●	●	●	●	●
Support for synchronous reluctance motor (SynRM)	+N7502	□	□	□ ¹¹⁾	□	□
Control panel						
Intuitive control panel		● ¹⁾	●	●	●	●
Integrated control panel holder in the drive		●	–	–	–	–
Control panel mounting platform DPMP-01 (flush) / DPMP-02 (surface)		■	–	–	–	–
Control connections (I/O) and communications						
2 pcs analog inputs, programmable, galvanically isolated		●	●	●	●	●
2 pcs analog outputs, programmable		●	●	●	●	●
6 pcs digital inputs, programmable, galvanically isolated - can be divided into two groups		●	●	●	●	●
2 pcs digital inputs/outputs		●	●	●	●	●
1 pcs digital input interlock		●	●	●	●	●
3 pcs relay outputs programmable		●	●	●	●	●
Safe torque off (STO)		●	●	●	●	●
Drive-to-drive link/Built-in Modbus		●	●	●	●	●
Assistant control panel/PC tool connection		●	●	●	●	●
Possibility for external power supply for control unit		●	●	●	●	●
Built-in I/O extension and speed feedback modules: for more details see sections: "Input/output extension modules for increased connectivity", "Speed feedback interfaces for precise process control" and "DDCS communication option modules"		□	□	□	□	□
Built-in adapters for several fieldbuses: for more details see section "Flexible connectivity to automation networks"		□	□	□	□	□
EMC filters						
EMC 1 st environment, unrestricted distribution (category C2)	+E202	□ ²⁾	□ ²⁾	□ ⁹⁾	□ ⁹⁾	□ ⁹⁾
EMC 2 nd environment, unrestricted distribution (category C3)	+E200	□ ³⁾	□ ³⁾	–	–	–
EMC 2 nd environment, unrestricted distribution (category C3)	+E201	□ ⁴⁾	□ ⁴⁾	–	–	–
EMC 2 nd environment, unrestricted distribution (category C3)	+E210	–	□ ⁵⁾	●	●	●

Summary of features and options

Power and voltage range	Ordering code	ACS880-01	ACS880-07	ACS880-07	ACS880-17	ACS880-37
		R1 to R9	R6 to R11	n×R8i	n×R8i ⁹⁾	n×R8i ⁹⁾
		kW	kW	kW	kW	kW
230 V		0.55 to 75	45 to 500	400 to 1400	160 to 1200	160 to 1200
400 V		0.55 to 250	45 to 630	560 to 1400	200 to 1600	200 to 1600
500 V		0.55 to 250	45 to 710	560 to 2800	200 to 3200	200 to 3200
690 V		4 to 250				
Line filter						
AC or DC choke		●	●	●	–	–
LCL		–	–	–	●	●
Output filters						
Common mode filter	+E208	□	□	●	●	●
du/dt filters	+E205	■	□	●	●	●
Braking (see braking unit table)						
Brake chopper	+D150	□ ⁶⁾	□	□ ⁷⁾	–	□ ⁷⁾
Brake resistor	+D151	■	□	□ ⁷⁾	–	□ ⁷⁾
Rectifier bridge						
12-pulse	+A004	–	–	□	–	–
Line side apparatus						
aR line fuses		–	●	●	●	●
Main switch		–	●	●	●	●
Line contactor	+F250	–	□	□ ¹³⁾	● ¹⁴⁾	● ¹⁴⁾
Air circuit breaker	+F255	–	–	□ ⁸⁾	● ¹⁵⁾	● ¹⁵⁾
Earthing switch	+F259	–	–	□	□	□
Cabinet options						
Cabinet heater (ext. supply)	+G300	–	□	□	□	□
Output for motor heater (ext. supply)	+G313	–	□	□	□	□
Customized options	+P902	–	□	□	□	□
Safety functions						
Safe torque off (STO)		●	●	●	●	●
Safety functions module, FSO-12, without encoder, programmable functions:	+Q973	□	□	□	□	□
Safe stop 1 (SS1)						
Safely-limited speed (SLS)						
Safe brake control (SBC)						
Safe maximum speed (SMS)						
Safe stop emergency (SSE)						
Prevention of unexpected startup (POUS)						
Safety functions module, FSO-21, with encoder support, programmable functions:	+Q972 ¹¹⁾	□	□	□	□	□
Safe stop 1 (SS1)						
Safely-limited speed (SLS)						
Safe brake control (SBC)				□		
Safe maximum speed (SMS)						
Safe stop emergency (SSE)						
Prevention of unexpected startup (POUS)						
Safe direction (SDI), requires encoder feedback, FSE-31						
Safe speed monitoring (SSM)						
Pulse encoder interface module, FSE-31	+L521 ¹¹⁾					
PROFIsafe over profinet	+Q982	□	□	□	□	□
Prevention of unexpected startup with safety relay	+Q957	–	□	□	□	□
Prevention of unexpected startup with FSO-12 and -21	+Q950	–	□	□	□	□
Emergency stop, category 0 with opening the main contactor/breaker, with safety relay	+Q951	–	□	□	□	□
Emergency stop, category 1 with opening the main contactor/breaker, with safety relay	+Q952	–	□	□	□	□
Emergency stop, category 0 with STO, with safety relay	+Q963	–	□	□	□	□
Emergency stop, category 1 with STO, with safety relay	+Q964	–	□	□	□	□
Emergency stop, configurable category 0 or 1 with opening the main contactor/breaker, with FSO-12 and -21	+Q978	–	□	□	□	□
Emergency stop, configurable category 0 or 1 with STO and FSO-12 and -21	+Q979	–	□	□	□	□
Safely-limited speed with encoder, with FSO-21 and FSE-31	+Q965	–	□	□	□	□
Earth fault monitoring, earthed mains		●	●	●	●	●
Earth fault monitoring, unearthed mains	+Q954	–	□	□	□	□
ATEX thermal motor protection PTC/Pt100, Ex II (2) GD	+L513/+L514, +Q971	□ ¹¹⁾	□	□	□ ⁹⁾	□ ⁹⁾

Summary of features and options

Power and voltage range	Ordering code	ACS880-01	ACS880-07	ACS880-07	ACS880-17	ACS880-37
		R1 to R9	R6 to R11	n×R8i	n×R8i ⁹⁾	n×R8i ⁹⁾
		kW	kW	kW	kW	kW
230 V		0.55 to 75	45 to 500	400 to 1400	160 to 1200	160 to 1200
400 V		0.55 to 250	45 to 630	560 to 1400	200 to 1600	200 to 1600
500 V		0.55 to 250	45 to 630	560 to 1400	200 to 1600	200 to 1600
690 V		4 to 250	45 to 710	560 to 2800	200 to 3200	200 to 3200

Approvals						
CE		●	●	●	●	●
UL, cUL	+C121	●	□ ¹⁰⁾	□	□	□
CSA	+C134	●	□ ⁹⁾	□ ⁹⁾	□	□
EAC/GOST R ¹²⁾		●	●	●	●	●
RoHS		●	●	●	●	●
C-Tick		●	●	●	●	●
Marine type approvals	+C121 ¹⁸⁾ +C132 ¹⁹⁾	□ ¹⁷⁾	□	□	□	□
TÜV nord certificate for safety functions	+Q973	●	□	□	□ ⁹⁾	□ ⁹⁾
VTT ATEX protective device certificate	+Q973	□	□	□	□	□

- Standard
- Selectable option, with plus code
- Selectable option, external, no plus code
- Not available

Notes

- ¹⁾ Without control panel, +0J400
- ²⁾ Earthed network, frame sizes R1 to R9, 380 to 500 V
- ³⁾ Earthed network, frame sizes R6 to R9 (-01, -07), 380 to 500 V. Frame sizes R10 to R11 (-07) 690 V

- ⁴⁾ Unearthed network, frame sizes R6 to R9 380 to 500 V, frame sizes R7 to R11, 690 V
- ⁵⁾ Earthed/unearthed network, frame sizes R10 to R11 (380 to 500 V)
- ⁶⁾ Frame sizes R1 to R4 built-in and R5 to R9 as selectable option
- ⁷⁾ 2×R8i
- ⁸⁾ 2×D8T to 4×D8T
- ⁹⁾ Check availability from local ABB
- ¹⁰⁾ Frame sizes R10 to R11 pending
- ¹¹⁾ Pending
- ¹²⁾ EAC has replaced GOST R

- ¹³⁾ D8T, 2×D7T and 2×D8T
- ¹⁴⁾ R8i to 2×R8i, 400 to 500 V. R8i to 3×R8i, 690 V
- ¹⁵⁾ 3×R8i, 400 to 500 V. 4×R8i and 6×R8i, 690 V
- ¹⁶⁾ Safe Disconnection Function (+Q971), does not include an ATEX relay
- ¹⁷⁾ Marine type approvals for ACS880-01 (ABS, Bureau veritas, CCS, DNV GL, Lloyd's, NK, RINA)
- ¹⁸⁾ For cabinet-built drives (-07)
- ¹⁹⁾ For wall-mounted drives (-01)
- ²⁰⁾ Available only with IP20 (P940 or P944)

Drives service

Your choice, your future

The future of your drives depends on the service you choose.

Whatever you choose, it should be a well-informed decision. No guesswork. We have the expertise and experience to help you find and implement the right service for your drive equipment. You can start by asking yourself these two critical questions:

- Why should my drive be serviced?
- What would my optimal service options be?

From here, you have our guidance and full support along the course you take, throughout the entire lifetime of your drives.

Your choice, your business efficiency

ABB Drive Care agreement lets you focus on your core business. A selection of predefined service options matching your needs provides optimal, more reliable performance, extended drive lifetime and improved cost control. So you can reduce the risk of unplanned downtime and find it easier to budget for maintenance.

We can help you more by knowing where you are!

Register your drive at www.abb.com/drivereg for extended warranty options and other benefits.



Service to match your needs

Your service needs depend on your operation, life cycle of your equipment and business priorities. We have identified our customers' four most common needs and defined service options to satisfy them. What is your choice to keep your drives at peak performance?

Is uptime your priority?

Keep your drives running with precisely planned and executed maintenance.

Example services include:

- ✓ Life Cycle Assessment
- ✓ Installation and Commissioning
- ✓ Spare Parts
- ✓ Preventive Maintenance
- ✓ Reconditioning

Is rapid response a key consideration?

If your drives require immediate action, our global network is at your service.

Example services include:

- ✓ Technical Support
- ✓ Drive Exchange
- ✓ On-site Repair
- ✓ Remote Support
- ✓ Response time agreements

Need to extend your assets' lifetime?

Maximize your drive's lifetime with our services.

Example services include:

- ✓ Life Cycle Assessment
- ✓ Control Upgrades
- ✓ Retrofits
- ✓ Replacement, Disposal and Recycling

Is performance most critical to your operation?

Get optimal performance out of your machinery and systems.

Example services include:

- ✓ Training
- ✓ Inspections and Diagnostics
- ✓ Hardware Upgrades
- ✓ Retrofits
- ✓ Workshop Repair



Drives service

A lifetime of peak performance

You're in control of every life cycle phase of your drives. At the heart of drive services is a four-phase product life cycle management model. This model defines the services recommended and available throughout drives lifespan.

Now it's easy for you to see the exact service and maintenance available for your drives.

ABB drives life cycle phases explained:

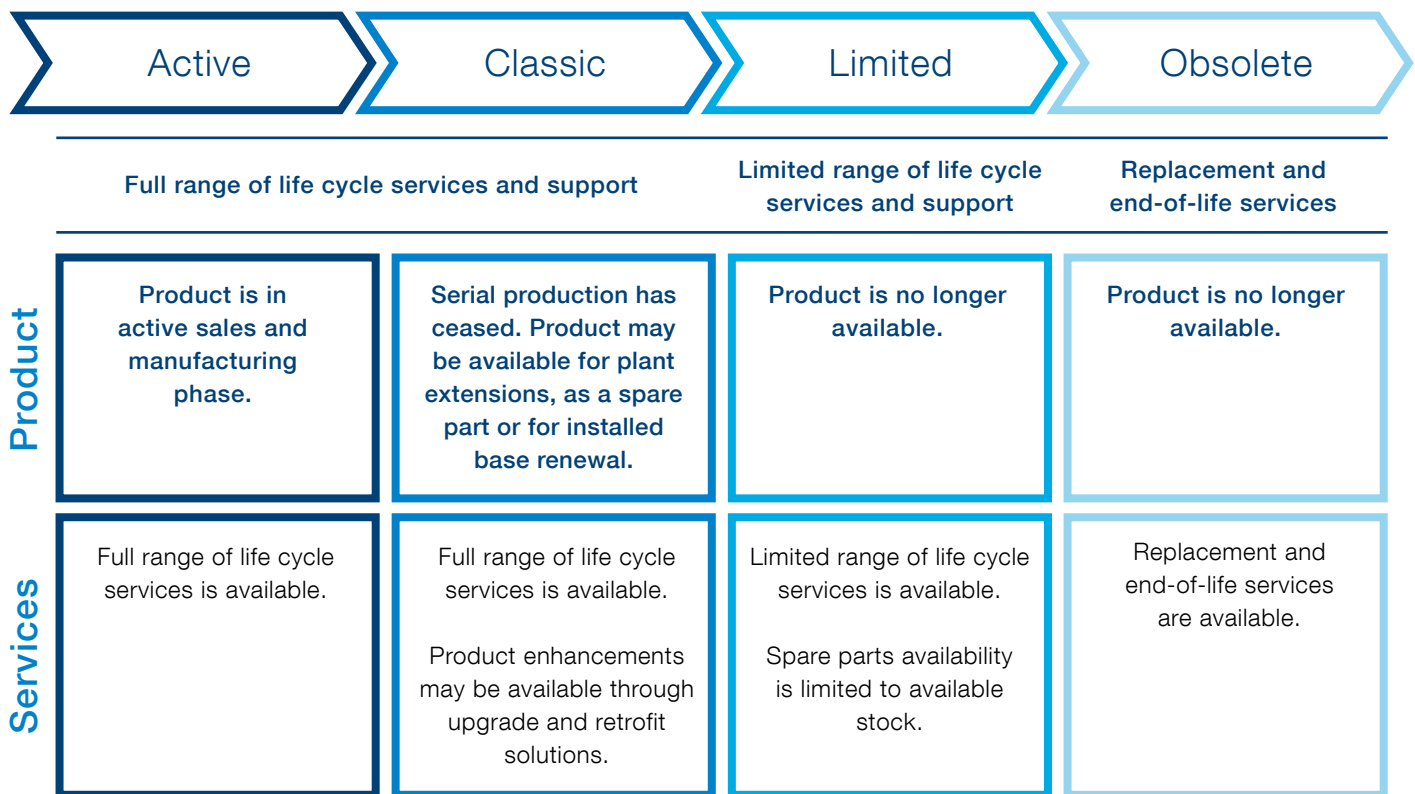

Keeping you informed

We notify you every step of the way using life cycle status statements and announcements.

Your benefit is clear information about your drives' status and precise services available. It helps you plan the preferred service actions ahead of time and make sure that continuous support is always available.

Step 1 Life Cycle Status Announcement

Provides early information about the upcoming life cycle phase change and how it affects the availability of services.

Step 2 Life Cycle Status Statement

Provides information about the drive's current life cycle status, availability of product and services, life cycle plan and recommended actions.

Contact us

For more information please contact your local ABB representative or visit:

www.abb.com/drives
www.abb.com/drivespartners

© Copyright 2015 ABB. All rights reserved.
Specifications subject to change without notice.



ACS880 single
drives web page

3AUJA000098111 REV/K EN 3.7.2015 *12118